

SRI LANKA RAILWAYS

Invitation for Bids (IFB)

PROCUREMENT OF 45,000 NOS. HIGH FRICTION COMPOSITE BRAKE BLOCKS

SRS/F.8017

1. The Chairman, Department Procurement Committee (Major) on behalf of Sri Lanka Railways, Railway Head Quarters, P.O. Box 355, Colombo, Sri Lanka will receive sealed bids from eligible and qualified bidders for the Supply of 45,000 Nos. High Friction Composite Brake Blocks to Sri Lanka Railways. Bidders may submit their bids through an accredited agent empowered by them with Power of Attorney.
2. Bidding will be conducted through **International Competitive Bidding**.
3. Interested eligible bidders may obtain further information and inspect the Bidding Documents at the address given below from 9.00am to 3.00pm.

**Deputy General Manager (Procurement),
Railway Procurement Sub Department,
Olcott Mawatha,
Colombo 10, Sri Lanka.**

Telephone Nos. : 94 (11) 2438078 or 94(11) 4600202
Fax No. : 94(11) 2432044
Email : srs.slr@gmail.com, tender1@railway.gov.lk
Website : www.railway.gov.lk

4. The manufacturer of the item shall have experience of more than five (05) years in manufacturing and supplying High Friction Composite Brake Blocks for the use of air brake operated Railway coaches/DMU.
5. The bidder should have ISO 9001:2008 or equivalent for manufacturing High Friction Brake Blocks for more than 05 years or the manufacturer/Supplier should have completed at least three (03) years and one out of which should be to a foreign Railway.
6. a. Any person who acts as an agent or sub agent, representative or nominee for or on behalf of any bidder shall register himself before submission of bids with Registrar of Public Contracts Sri Lanka, as required by the Public Contract Act No.03 of 1987. The Original Certificate of registration shall be submitted with the bid. The bids of those bidders who fail to submit such original certificate shall be rejected.
b. The bidders shall also register themselves immediately after submission of the bids and prior to the award of the procurement, in terms of the Public Contract Act No.03 of 1987. The procurement shall not be awarded to any bidder unless such bidder had submitted the Certificate of Registration issued in terms of the Public Contracts Act to the relevant Procurement Committee.
7. A complete set of Bidding Documents in English Language may be purchased by interested bidders on the submission of a written application to the address of the **Deputy General Manager (Procurement), Railway Procurement Sub Department, Olcott Mawatha, Colombo 10, Sri Lanka.** or Sri Lanka Missions abroad from **05/12/2024 to 21/01/2025 up to 3.00 p.m.** (Sri Lanka Time) on payment of a non-refundable procurement fee of **Rs. 53,000/-** only or an equivalent sum in a freely convertible currency.
8. Bids must be delivered to the address below **on or before 2.00 p.m. on 22/01/2025**
The Chairman,
Department Procurement Committee (Major)
Sri Lanka Railways
Railway Procurement Sub Department
Olcott Mawatha, Colombo 10, Sri Lanka.

Late bids will be rejected. Bids will be opened in the presence of the bidders' representatives at **Room No. 01, 3rd Floor, Railway Procurement Sub Department, P.B. 1347, Olcott Mawatha, Colombo 10, Sri Lanka at 2.00 p.m. on 22/01/2025.**

The Chairman,
Department Procurement Committee (Major),
Sri Lanka Railways.

Ref. No. SRS/F.8017

SRI LANKA RAILWAYS

PROCUREMENT OF 45,000 NOS. HIGH FRICTION COMPOSITE BRAKE BLOCKS

BIDDING DOCUMENT ISSUED UP TO	-	21/01/2025
CLOSING /OPENING OF BIDS	-	22/01/2025

DOCUMENT NUMBER :

ISSUED TO:

M/s. :.....

ADDRESS

.....

.....

.....

Amount Collected: Rs. 53,000/-

Receipt No: of

DATE:

.....

SIGNATURE OF ISSUING OFFICER

**PROCUREMENT OF 45,000 NOS. HIGH FRICTION COMPOSITE BRAKE
BLOCKS**

INTERNATIONAL COMPETITIVE BIDDING DOCUMENT

VOLUME 1

**SECTION -I INSTRUCTIONS TO BIDDERS (ITB)
SECTION -VI CONDITIONS OF CONTRACT (CC)
SECTION -VIII CONTRACT FORMS**

VOLUME 2

**SECTION II BIDDING DATA SHEET (BDS)
SECTION III EVALUATION AND QUALIFYING CRITERIA
SECTION IV BIDDING FORMS
SECTION V SCHEDULE OF REQUIREMENTS
SECTION VII CONTRACT DATA
INVITATION FOR BIDS**

**Department Procurement Committee (Major),
Sri Lanka Railways,
Olcott Mawatha,
Colombo 10,
Sri Lanka.**

SECTION -I INSTRUCTIONS TO BIDDERS

SECTION -VI CONDITIONS OF CONTRACT (CC)

SECTION -VIII CONTRACT FORMS

SECTION 1

INSTRUCTIONS TO BIDDERS (ITB)

Section I. Instructions to Bidders (ITB)

ITB shall be read in conjunction with Section II, Bidding Data Sheet (BDS), which shall take precedence over ITB.

General

1. Scope of Bid

1.1 The Purchaser indicated in the Bidding Data Sheet (BDS), issues these Bidding Documents for the supply of Goods and Related Services incidental thereto as specified in Section V, Schedule of Requirements. The name and identification number of this procurement are specified in the BDS. The name, identification, and number of lots (individual contracts), if any, are provided in the BDS.

1.2 Throughout these Bidding Documents

(a) the term “in writing” means communicated in written form by mail (other than electronic mail) or hand delivered with proof of receipt;

(b) if the context so requires, “singular” means “plural” and vice versa; and

(c) “day” means calendar day.

2. Source of Funds

2.1 Payments under this contract will be financed by the source specified in the BDS.

3. Ethics, Fraud and Corruption

3.1 The attention of the bidders is drawn to the following guidelines of the Procurement Guidelines published by National Procurement Agency:

Parties associated with Procurement Actions, namely, suppliers/contractors and officials shall ensure that they maintain strict confidentiality throughout the process;

Officials shall refrain from receiving any personal gain from any Procurement Action. No gifts or inducement shall be accepted. Suppliers/Contractors are liable to be disqualified from the bidding process if found offering any gift or inducement which may have an effect of influencing a decision or impairing the objectivity of an official.

3.2 The Purchaser requires the Bidders, Suppliers, Contractors, and Consultants to observe the highest standard of ethics during the procurement and execution of such Contracts.

In pursuit of this policy:

- (a) “Corrupt Practice” means the offering, giving, receiving, or soliciting directly or indirectly, of anything of value to influence the action of a public official in the procurement process or in contract execution;
- (b) “Fraudulent Practice” means a misrepresentation or omission of facts in order to influence a procurement process or the execution of a contract;
- (c) “Collusive Practice” means a scheme or arrangement between two or more bidders, with or without the knowledge of the Purchaser to establish bid prices at artificial, non-competitive levels; and
- (d) “Coercive Practice” means harming or threatening to harm, directly or indirectly, persons or their property to influence their participation in the procurement process or affect the execution of a contract.

3.3 If the Purchaser found any unethical practice as stipulated under ITB Clause 3.2, the Purchaser will reject the bid, If it is found that a Bidder directly or through an agent, engaged in corrupt, fraudulent, collusive or coercive practice in competing for the Contract in question.

4. Eligible Bidders

4.1 All bidders shall possess legal rights to supply the Goods under this contract.

4.2 A Bidder shall not have a conflict of interest. All bidders found to have conflict of interest shall be disqualified. Bidders may be considered to have a conflict of interest with one or more parties in this bidding process, if they:

- (a) are or have been associated in the past, with a firm or any of its affiliates which have been engaged by the Purchaser to provide consulting services for the preparation of the design, specifications, and other documents to be used for the procurement of the goods to be purchased under these Bidding Documents ; or
- (b) submit more than one bid in this bidding process. However, this does not limit the participation of subcontractors in more than one bid.

4.3 Foreign Bidder may submit a bid only if so stated in the BDS.

5. Eligible Goods and Related Services

5.1 All goods supplied under this contract shall be complied with applicable standards stipulated by the Sri Lanka Standard Institute. (SLSI). In the absence of such standards, the Goods supplied shall be complied with other internationally accepted standards.

Contents of Bidding Documents

6. Section of Bidding Documents

6.1 The Bidding Documents consist of 2 Volumes, which include all the sections indicated below, and should be read in conjunction with any addendum issued in accordance with ITB Clause 8.

Volume 1

- Section I. Instructions to Bidders (ITB)
- Section VI. Conditions of Contract (CC)
- Section VIII. Contract Forms

Volume 2

- Section II. Bidding Data Sheet (BDS)
- Section III. Evaluation and Qualification Criteria
- Section IV. Bidding Forms
- Section V. Schedule of Requirements
- Section VII. Contract Data
- Invitation for Bid

6.2 The Bidder is expected to examine all instructions, forms, terms, and specifications in the Bidding Documents. Failure to furnish all information or documentation required by the Bidding Documents may result in the rejection of the bid.

7. Clarification of Bidding Documents

7.1 A prospective Bidder requiring any clarification of the Bidding Documents including the restrictiveness of specifications shall contact the Purchaser in writing at the Purchaser's address specified in the BDS (ITB 7.1). The Purchaser will respond in writing to any request for clarification, provided that such request is received **not later than 14 days prior to the deadline for submission of bids**. The Purchaser shall forward copies of its response to all those who have purchased the Bidding Documents, including a description of the inquiry but without identifying its source. Should the Purchaser deem it necessary to amend the Bidding Documents as a result of a clarification, it shall do so following the procedure under ITB Clause 8.

8. Amendment of Bidding Documents

8.1 At any time prior to the deadline for submission of bids, the Purchaser may amend the Bidding Documents by issuing addendum.

8.2 Any addendum issued shall be part of the Bidding Documents and shall be communicated in writing to all who have purchased the Bidding Documents.

8.3 To give prospective Bidders reasonable time in which to take an addendum into account in preparing their bids, the Purchaser may, at its discretion, extend the deadline for the submission of bids, pursuant to ITB Sub-Clause 23.2

Preparation of Bids

- 9. Cost of Bidding** 9.1 The Bidder shall bear all costs associated with the preparation and submission of its bid, and the Purchaser shall not be responsible or liable for those costs, regardless of the conduct or outcome of the bidding process.
- 10. Language of Bid** 10.1 The Bid, as well as all correspondence and documents relating to the Bid (including supporting documents and printed literature) exchanged by the Bidder and the Purchaser, shall be written in English language.
- 11. Documents Comprising the Bid** 11.1 The Bid shall comprise the following:
- (a) Bid Submission Form and the applicable Price Schedules, in accordance with ITB Clauses 12, 14, and 15; (Section 1.)
 - (b) Bid Security or Bid-Securing Declaration, in accordance with ITB Clause 20.:(Section 1.)
 - (c) Documentary evidence in accordance with ITB Clauses 18 and 29 (Section 1).
 - (d) that the Goods and Related Services conform to the Bidding Documents;
 - (e) documentary evidence in accordance with ITB Clause 18 establishing the Bidder's qualifications to perform the contract if its bid is accepted; and
 - (f) any other document required in the BDS.
- 12. Bid Submission Form and Price Schedules** 12.1 The Bidder shall submit the Bid Submission Form using the form furnished in Section IV, Bidding Forms. This form must be completed without any alterations to its format, and no substitutes shall be accepted. All blank spaces shall be filled in with the information requested
- 13. Alternative Bids** 13.1 Alternative bids shall not be considered.
- 14. Bid Prices and Discounts** 14.1 The Bidder shall indicate on the Price Schedule the unit prices and total bid prices of the goods it proposes to supply under the Contract.
- 14.2 Any discount offered against any single item in the price schedule shall be included in the unit price of the item. However, a Bidder wishes to offer discount as a lot the bidder may do so by indicating such amounts appropriately.
- 14.3 If so indicated in ITB Sub-Clause 1.1, bids are being invited for individual contracts (lots) or for any combination of contracts (packages). Unless otherwise indicated in the BDS, prices quoted shall correspond to 100 % of the items specified for each lot and to 100% of the quantities specified for each item of a lot. Bidders wishing to offer any price reduction (discount) for the award of more than one Contract shall specify the applicable price reduction separately.
- 14.4 (i) Prices indicated on the Price Schedule shall include all duties and sales and other taxes already paid or payable by the Supplier:

- (a) on components and raw material used in the manufacture or assembly of goods quoted; or
 - (b) on the previously imported goods of foreign origin .
 - (ii) However, VAT shall not be included in the price but shall be indicated separately;
 - (iii) the price for inland transportation, insurance and other related services to deliver the goods to their final destination;
 - (iv) the price of other incidental services
- 14.5 The Prices quoted by the Bidder shall be fixed during the Bidder's performance of the Contract and not subject to variation on any account. A bid submitted with an adjustable price quotation will be treated as non-responsive and rejected, pursuant to ITB Clause 31.
- 14.6 All lots, if any, and items must be listed and priced separately in the Price Schedules. If a Price Schedule shows items listed but not priced, their prices shall be assumed to be included in the prices of other items.
- 15. Currencies of Bid** 15.1 Unless otherwise stated in Bidding Data Sheet, the Bidder shall quote in Sri Lankan Rupees and payment shall be payable only in Sri Lankan Rupees.
- 16. Documents Establishing the Eligibility of the Bidder** 16.1 To establish their eligibility in accordance with ITB Clause 4, Bidders shall complete the Bid Submission Form, included in Section IV, Bidding Forms.
- 17. Documents Establishing the Conformity of the Goods and Related Services**
- 17.1 To establish the conformity of the Goods and Related Services to the Bidding Documents, the Bidder shall furnish as part of its Bid the documentary evidence that the Goods conform to the technical specifications and standards specified in Section V, Schedule of Requirements.
- 17.2 The documentary evidence shall be in the form of literature, drawings or data, and shall consist of a detailed item by item description (given in Section V, Technical Specifications) of the essential technical and performance characteristics of the Goods and Related Services, demonstrating substantial responsiveness of the Goods and Related Services to the technical specification, and if applicable, a statement of deviations and exceptions to the provisions of the Schedule of Requirements.
- 17.3 The Bidder shall also furnish a list giving full particulars, including quantities, available sources and current prices of spare parts, special tools, etc., necessary for the proper and continuing functioning of the Goods during the period if specified in the BDS following commencement of the use of the goods by the Purchaser.
- 18. Documents Establishing the Qualifications** 18.1 The documentary evidence of the Bidder's qualifications to perform the contract if its bid is accepted shall establish to the Purchaser's satisfaction:

- of the Bidder**
- (a) A Bidder that does not manufacture or produce the Goods it offers to supply shall submit the Manufacturer's Authorization using the form included in Section IV, Bidding Forms to demonstrate that it has been duly authorized by the manufacturer or producer of the Goods to supply these Goods;
 - (b) that, if required in the BDS , in case of a Bidder not doing business within Sri Lanka, the Bidder is or will be (if awarded the contract) represented by an Agent in Sri Lanka equipped and able to carry out the Supplier's maintenance, repair and spare parts-stocking obligations prescribed in the Conditions of Contract and/or Technical Specifications; and
 - (c) that the Bidder meets each of the qualification criteria specified in Section III, Evaluation and Qualification Criteria.
- 19. Period of Validity of Bids**
- 19.1 Bids shall remain valid until the date specified in the BDS. A bid valid for a shorter date shall be rejected by the Purchaser as Non Responsive.
- 19.2 In exceptional circumstances, prior to the expiration of the bid validity date, the Purchaser may request bidders to extend the period of validity of their bids. The request and the responses shall be made in writing. If a Bid Security is requested in accordance with ITB Clause 20, it shall also be extended for a corresponding period. A Bidder may refuse the request without forfeiting its Bid Security. A Bidder granting the request shall not be required or permitted to modify its bid.
- 20. Bid Security**
- 20.1 The Bidder shall furnish as part of its bid, a Bid Security or a Bid-Securing Declaration, as specified in the BDS.
- 20.2 The Bid Security shall be in the amount specified in the BDS. and denominated in Sri Lankan Rupees, and shall:
- (a) at the bidder's option, be in the form of a bank guarantee from a banking institution;
 - (b) be issued by an institution acceptable to the Purchaser. The acceptable institutes are published in the Public Finance Website.
 - (c) be substantially in accordance with the form included in Section IV, Bidding Forms.
 - (d) be payable promptly upon written demand by the Purchaser in case the conditions listed in ITB Clause 20.5 are invoked;
 - (e) be submitted in its original form. Copies will not be accepted.
 - (f) Remain valid for the period specified in the BDS.
- 20.3 Any bid not accompanied by a substantially responsive Bid Security or Bid Securing Declaration in accordance with ITB Sub-Clause 20.1 and 20.2, may be rejected by the Purchaser as non-responsive.

- 20.4 The Bid Security of unsuccessful Bidders shall be returned as promptly as possible upon the successful Bidder's furnishing of the Performance Security pursuant to ITB Clause 43.
- 20.5 The Bid Security may be forfeited or the Bid Securing Declaration executed:
- (a) if a Bidder withdraws its bid during the period of bid validity specified by the Bidder on the Bid Submission Form, except as provided in ITB Sub-Clause 19.2; or
 - (b) if a Bidder does not agree to correction of arithmetical errors in pursuant to ITB Sub-Clause 30.3
 - (c) if the successful Bidder fails to:
 - (i) sign the Contract in accordance with ITB Clause 42;
 - (ii) furnish a Performance Security in accordance with ITB Clause 43.

21. Format and Signing of Bid

- 21.1 The Bidder shall prepare one original of the documents comprising the bid as described in ITB Clause 11 and clearly mark it as "ORIGINAL." In addition, the Bidder shall submit a copy of the bid and clearly mark it as "COPY." In the event of any discrepancy between the original and the copy, the original shall prevail.
- 21.2 The original and the Copy of the bid shall be typed or written in indelible ink and shall be signed by a person duly authorized to sign on behalf of the Bidder.
- 21.3 Any interlineations, erasures, or overwriting shall be valid only if they are signed or initialed by the person signing the Bid.

Submission and Opening of Bids

22. Submission, Sealing and Marking of Bids

- 22.1 Bidders may always submit their bids by mail or by hand.
- (a) Bidders submitting bids by mail or by hand, shall enclose the original and the copy of the Bid in separate sealed envelopes, duly marking the envelopes as "ORIGINAL" and "COPY." These envelopes containing the original and the copy shall then be enclosed in one single envelope.
- 22.2 The inner and outer envelopes shall:
- (a) Bear the name and address of the Bidder;
 - (b) be addressed to the Purchaser in accordance with ITB Sub-

Clause 23.1;

- (c) bear the specific identification of this bidding process as indicated in the BDS; and
- (d) bear a warning not to open before the time and date for bid opening, in accordance with ITB Sub-Clause 26.1.

If all envelopes are not sealed and marked as required, the Purchaser will assume no responsibility for the misplacement or premature opening of the bid.

23. Deadline for Submission of Bids

- 23.1 Bids must be received by the Purchaser at the address and no later than the date and time specified in the BDS – ITB 22.2 (c), 23.1.
- 23.2 The Purchaser may, at its discretion, extend the deadline for the submission of bids by amending the Bidding Documents in accordance with ITB Clause 8, in which case all rights and obligations of the Purchaser and Bidders previously subject to the deadline shall thereafter be subject to the deadline as extended.

24. Late Bids

- 24.1 The Purchaser shall not consider any bid that arrives after the deadline for submission of bids, in accordance with ITB Clause 23. Any bid received by the Purchaser after the deadline for submission of bids shall be declared late, rejected, and returned unopened to the Bidder.

25. Withdrawal, and Modification of Bids

- 25.1 A Bidder may withdraw, or modify its Bid after it has been submitted by sending a written notice in accordance with ITB Clause 22, duly signed by an authorized representative, and shall include a copy of the authorization in accordance with ITB Sub-Clause 21.2, (except that no copies of the withdrawal notice are required). The corresponding substitution or modification of the bid must accompany the respective written notice. All notices must be:
 - (a) submitted in accordance with ITB Clauses 21 and 22 (except that withdrawal notices do not require copies), and in addition, the respective envelopes shall be clearly marked “WITHDRAWAL,” or “MODIFICATION;” and
 - (b) Received by the Purchaser prior to the deadline prescribed for submission of bids, in accordance with ITB Clause 23.
- 25.2 Bids requested to be withdrawn in accordance with ITB Sub-Clause 25.1 shall be returned to the Bidders only upon notification of contract award to the successful bidder in accordance with sub clause 41.1.
- 25.3 No bid may be withdrawn, substituted, or modified in the interval

between the deadline for submission of bids and the expiration of the period of bid validity specified by the Bidder on the Bid Submission Form or any extension thereof.

26. Bid Opening

- 26.1 The Purchaser shall conduct the bid opening in public at the address, date and time specified in the BDS (ITB 16.1).
- 26.2 First, envelopes marked “WITHDRAWAL” shall be opened and read out and the envelope with the corresponding bid may be opened at the discretion of the Purchaser. No bid withdrawal shall be permitted unless the corresponding withdrawal notice contains a valid authorization to request the withdrawal and is read out at bid opening. Envelopes marked “MODIFICATION” shall be opened and read out with the corresponding Bid. No Bid modification shall be permitted unless the corresponding modification notice contains a valid authorization to request the modification and is read out at Bid opening. Only envelopes that are opened and read out at Bid opening shall be considered further.
- 26.3 All other envelopes shall be opened one at a time, reading out: the name of the Bidder and whether there is a modification; the Bid Prices, including any discounts and alternative offers; the presence of a Bid Security or Bid-Securing Declaration, if required; and any other details as the Purchaser may consider appropriate. Only discounts and alternative offers read out at Bid opening shall be considered for evaluation. No Bid shall be rejected at Bid opening except for late bids, in accordance with ITB Sub-Clause 24.1.
- 26.4 The Purchaser shall prepare a record of the Bid opening that shall include, as a minimum: the name of the Bidder and whether there is a withdrawal, or modification; the Bid Price, per lot if applicable, including any discounts, and the presence or absence of a Bid Security or Bid-Securing Declaration. The bids that were opened shall be resealed in separate envelopes, promptly after the bid opening. The Bidders’ representatives who are present shall be requested to sign the attendance sheet. A copy of the record shall be distributed to all Bidders who submitted bids in time.

Evaluation and Comparison of Bids

27. Confidentiality

- 27.1 Information relating to the examination, evaluation, comparison, and post-qualification (if applicable) of bids, and recommendation of contract award, shall not be disclosed to bidders or any other persons not officially concerned with such process until publication of the Contract Award.
- 27.2 Any effort by a Bidder to influence the Purchaser in the examination, evaluation, comparison, and post-qualification of the bids or contract award decisions may result in the rejection of its Bid.
- 27.3 Notwithstanding ITB Sub-Clause 27.2, if any Bidder wishes to contact the Purchaser on any matter related to the bidding process, from the time of bid opening to the time of Contract Award, it should do so in writing.

- 28. Clarification of Bids** 28.1 To assist in the examination, evaluation, comparison and post-qualification of the bids, the Purchaser may, at its discretion, request any Bidder for a clarification of its Bid. Any clarification submitted by a Bidder in respect to its Bid and that is not in response to a request by the Purchaser shall not be considered for purpose of evaluation. The Purchaser's request for clarification and the response shall be in writing. No change in the prices or substance of the Bid shall be sought, offered, or permitted, except to confirm the correction of arithmetic errors discovered by the Purchaser in the Evaluation of the bids, in accordance with ITB Clause 30.
- 29. Responsiveness of Bids** 29.1 The Purchaser's determination of a bid's responsiveness is to be based on the contents of the bid itself.
- 29.2 A substantially responsive Bid is one that conforms to all the terms, conditions, and specifications of the Bidding Documents without material deviation, reservation, or omission. A material deviation, reservation, or omission is one that:
- (a) affects in any substantial way the scope, quality, or performance of the Goods and Related Services specified in the Contract; or
 - (b) limits in any substantial way, inconsistent with the Bidding Documents, the Purchaser's rights or the Bidder's obligations under the Contract; or
 - (c) if rectified would unfairly affect the competitive position of other bidders presenting substantially responsive bids.
- 29.3 If a bid is not substantially responsive to the Bidding Documents, it shall be rejected by the Purchaser and may not subsequently be made responsive by the Bidder by correction of the material deviation, reservation, or omission.
- 30. Nonconformities, Errors and Omissions** 30.1 Provided that a Bid is substantially responsive, the Purchaser may waive any non-conformities or omissions in the Bid that do not constitute a material deviation.
- 30.2 Provided that a bid is substantially responsive, the Purchaser may request that the Bidder submit the necessary information or documentation, within a reasonable period of time, to rectify nonmaterial nonconformities or omissions in the bid related to documentation requirements. Such omission shall not be related to any aspect of the price of the Bid. Failure of the Bidder to comply with the request may result in the rejection of its Bid.
- 30.3 Provided that the Bid is substantially responsive, the Purchaser shall correct arithmetical errors on the following basis:
- (a) if there is a discrepancy between the unit price and the line item total that is obtained by multiplying the unit price by the quantity, the unit price shall prevail and the line item total shall be corrected, unless in the opinion of the

Purchaser there is an obvious misplacement of the decimal point in the unit price, in which case the line item total as quoted shall govern and the unit price shall be corrected;

- (b) if there is an error in a total corresponding to the addition or subtraction of subtotals, the subtotals shall prevail and the total shall be corrected; and
- (c) if there is a discrepancy between words and figures, the amount in words shall prevail, unless the amount expressed in words is related to an arithmetic error, in which case the amount in figures shall prevail subject to (a) and (b) above.

30.4 If the Bidder that submitted the lowest evaluated Bid does not accept the correction of errors, its Bid shall be disqualified and its Bid Security shall be forfeited or its Bid-Securing Declaration shall be executed.

31. Preliminary Examination of Bids

31.1 The Purchaser shall examine the bids to confirm that all documents and technical documentation requested in ITB Clause 11 have been provided, and to determine the completeness of each document submitted.

31.2 The Purchaser shall confirm that the following documents and information have been provided in the Bid. If any of these documents or information is missing, the Bid shall be rejected.

- (a) Bid Submission Form, in accordance with ITB Sub Clause 12.1 :
- (b) Price Schedules,

in accordance with ITB Sub-Clause 12;

(c) Bid Security or Bid Securing

Declaration, in

accordance with ITB Clause 20.

- 32. Examination of Terms and Conditions; Technical Evaluation**
- 32.1 The Purchaser shall examine the Bid to confirm that all terms and conditions specified in the CC and the Contract Data have been accepted by the Bidder without any material deviation or reservation.
- 32.2 The Purchaser shall evaluate the technical aspects of the Bid submitted in accordance with ITB Clause 17, to confirm that all requirements specified in Section V, Schedule of Requirements of the Bidding Documents have been met without any material deviation or reservation.
- 32.3 If, after the examination of the terms and conditions and the technical evaluation, the Purchaser determines that the Bid is not substantially responsive in accordance with ITB Clause 29, the Purchaser shall reject the Bid.
- 33. Conversion to Single Currency**
- 33.1 If the bidders are allowed to quote in foreign currencies in accordance with sub clause 15.1, for evaluation and comparison purposes, the Purchaser shall convert all bid prices expressed in foreign currencies in to Sri Lankan Rupees using the selling rates prevailed on 25/12/2024 (28 days prior to closing of bids) as published by the Central Bank of Sri Lanka. If this date falls on a public holiday the earliest working day prior to the date shall be applicable.
- 34. Domestic Preference**
- 34.1 Domestic preference shall be a factor in bid evaluation only if stated in the RSS. If domestic preference shall be a bid-evaluation factor, the methodology for calculating the margin of preference and the criteria for its application shall be as specified in Section III, Evaluation and Qualification Criteria.
- 35. Evaluation of Bids**
- 35.1 The Purchaser shall evaluate each bid that has been determined, up to this stage of the evaluation, to be substantially responsive.
- 35.2 To evaluate a Bid, the Purchaser shall only use all the factors, methodologies and criteria defined in this ITB Clause 35.
- 35.3 To evaluate a bid the purchaser shall consider the following
- (a) the Bid Price as quoted in accordance with clause 14;
 - (b) price adjustment for correction of arithmetic errors in accordance with ITB Sub-Clause 30.3;
 - (c) price adjustment due to discounts offered in accordance with ITB Sub-Clause 14.2; and 14.3
 - (d) adjustments due to the application of the evaluation criteria specified in the BDS from amongst those set out in Section III, Evaluation and Qualification Criteria;
 - (e) Adjustments due to the application of a domestic preference, in accordance with ITB Clause 34 if applicable.
- 35.4 The Purchaser's evaluation of a bid may require the consideration of other factors, in addition to the factors listed in ITB Sub-Clause 35.3, if specified in BDS. These factors may be related to the characteristics, performance, and terms and conditions of purchase of the Goods and Related Services. The effect of the factors selected, if any, shall be expressed in monetary terms to

facilitate comparison of bids.

- 35.5 If so specified in the BDS, these Bidding Documents shall allow Bidders to quote for one or more lots, and shall allow the Purchaser to award one or multiple lots to more than one Bidder. The methodology of evaluation to determine the lowest-evaluated lot combinations is specified in Section III, Evaluation and Qualification Criteria.
- 36. Comparison of Bids** 36.1 The Purchaser shall compare all substantially responsive bids to determine the lowest-evaluated bid, in accordance with ITB Clause 35.
- 37. Post qualification of the Bidder.** 37.1 The Purchaser shall determine to its satisfaction whether the Bidder that is selected as having submitted the lowest evaluated and substantially responsive bid is qualified to perform the Contract satisfactorily.
- 37.2 The determination shall be based upon an examination of the documentary evidence of the Bidder's qualifications submitted by the Bidder, pursuant to ITB Clause 18.
- 37.3 An affirmative determination shall be a prerequisite for award of the Contract to the Bidder. A negative determination shall result in disqualification of the bid, in which event the Purchaser shall proceed to the next lowest evaluated bid to make a similar determination of that Bidder's capabilities to perform satisfactorily
- 38. Purchaser's Right to Accept Any Bid, and to Reject Any or All Bids** 38.1 The Purchaser reserves the right to accept or reject any bid, and to annul the bidding process and reject all bids at any time prior to contract award, without thereby incurring any liability to Bidders.

Award of Contract

- 39. Award Criteria** 39.1 The Purchaser shall award the Contract to the Bidder whose offer has been determined to be the lowest evaluated bid and is substantially responsive to the Bidding Documents, provided further that the Bidder is determined to be qualified to perform the Contract satisfactorily.
- 40. Purchaser's Right to Vary Quantities at Time of Award** 40.1 At the time the Contract is awarded, the Purchaser reserves the right to increase or decrease the quantity of Goods and Related Services originally specified in Section V, Schedule of Requirements, provided this does not exceed twenty five percent (25%) or one unit whichever is higher and without any change in the unit prices or other terms and conditions of the bid and the Bidding Documents.
- 41. Notification of Award** 41.1 Prior to the expiration of the period of bid validity, the Purchaser shall notify the successful Bidder, in writing, that its Bid has been accepted.
- 41.2 Until a formal Contract is prepared and executed, the notification of award shall constitute a binding Contract.

- 41.3 Upon the successful Bidder's furnishing of the signed Contract Form and performance security pursuant to ITB Clause 43, the Purchaser will promptly notify each unsuccessful Bidder and will discharge its bid security, pursuant to ITB Clause 20.4.
- 42. Signing of Contract**
- 42.1 Within Seven (7) days after notification, the Purchaser shall complete the Agreement, and inform the successful Bidder to sign it.
- 42.2 Within Fourteen (14) days of receipt of such information, the successful Bidder shall sign the Agreement.
- 43. Performance Security**
- 43.1 Within twenty one (21) days of the receipt of notification of award from the Purchaser, the successful Bidder, if required, shall furnish the Performance Security in accordance with the Conditions of Contract, using for that purpose the Performance Security Form included in Section VIII Contract forms. The Employer shall promptly notify the name of the winning Bidder to each unsuccessful Bidder and discharge the Bid Securities of the unsuccessful bidders pursuant to ITB Sub-Clause 20.4.
- 43.2 Failure of the successful Bidder to submit the above-mentioned Performance Security or sign the Contract shall constitute sufficient grounds for the annulment of the award and forfeiture of the Bid Security or execution of the Bid-Securing Declaration. In that event the Purchaser may award the Contract to the next lowest evaluated Bidder, whose offer is substantially responsive and is determined by the Purchaser to be qualified to perform the Contract satisfactorily.

44. Details Of Local Agent

If the value of the bid exceeds LKR 250million, the bidder shall furnish the following information along with the bid.

- i. The name and address of the Local Agent(s).
- ii. The year of registration of the business of the Local Agent(s).
- iii. A certified copy of the audited accounts of the Local Agent(s) for two consecutive years immediately preceding the date of submission of bids or proposals, audited by an independent external auditor in accordance with the Sri Lanka Accounting Standards, and
- iv. All details of commissions or gratuities, if any, paid or to be paid to the Local Agent(s) connected with or relating to the bid or proposal up to Contract execution if the bidder is awarded the Contract, including any fees payable.

45. Agent To Hold Power Of Attorney.

Offers from Agents representing Principal Manufacturers abroad, will not be considered, unless they hold the Power of Attorney from the principal manufacturer empowering the agent to offer on their behalf, to enter into a valid Agreement on behalf of the principals, and to fulfill all the terms and conditions of the contract, in the event of the Procurement being awarded.

Nomination of agent/s after the Bid has been submitted will not be

accepted. Agent nominated at the time of Bidding shall not be changed within the period of Contract.

46. Registration Of Contract

- a. Any person who act as an agent or sub-agent, representative or nominee for or on behalf of any bidder, shall register himself before submission of bids with Register of Public Contracts Sri Lanka, as required by the Public Contract Act No.3 of 1987. The original Certificate of Registration shall be submitted with the bid. The bids of those bidders who fail to submit such original certificate shall be rejected.
- b. The bidders shall also register themselves immediately after submission of the bids and prior to the award of the procurement, in terms of the Public Contract Act No. 03 of 1987. The procurement shall not be awarded to any bidder unless such bidder has submitted the Certificate of Registration issued in terms of the Public Contracts Act to the relevant Procurement Committee.
- c. The successful bidder shall provide the relevant particulars required by the Public Contracts Act No. 03 of 1987 to the Registrar of Public Contracts upon the award of the procurement.

SECTION VI CONDITIONS OF CONTRACT (CC)

Section VI. Conditions of Contract

Table of Clauses

1.	Definitions.....	21
2.	Contract Documents.....	22
3.	Fraud and Corruption.....	22
4.	Interpretation.....	22
5.	Language.....	23
6.	Joint Venture, Consortium or Association.....	23
7.	Eligibility.....	23
8.	Notice	23
9.	Governing Law.....	24
10.	Settlement of Disputes.....	24
11.	Scope of Supply.....	24
12.	Delivery and Documents.....	24
13.	Supplier's Responsibilities.....	24
14.	Contract Price.....	24
15.	Terms of Payments.....	24
16.	Taxes and Duties.....	25
17.	Performance Security	25
18.	Copy Right.....	25
19.	Confidential Information.....	25
20.	Subcontracting.....	26
21.	Specifications and Standards.....	26
22.	Packing and Documents.....	27
23.	Insurance.....	27

24.	Transportation.....	27
25.	Inspections and Tests.....	27
26.	Liquidated Damages.....	28
27.	Warranty.....	29
28.	Patent Indemnity.....	29
29.	Limitation of Liability.....	30
30.	Change in Laws and Regulations.....	31
31.	Force Majeure.....	31
32.	Change Orders and Contract Amendments.....	32
33.	Extension of Time.....	32
34.	Termination.....	33
35.	Assignment.....	34
36.	Country of Origin	34

Conditions of Contract

1. Definitions

1.1 The following words and expressions shall have the meanings hereby assigned to them:

- (a) “Contract” means the Contract Agreement entered into between the Purchaser and the Supplier, together with the Contract Documents referred to therein, including all attachments, appendices, and all documents incorporated by reference therein.
- (b) “Contract Documents” means the documents listed in the Contract Agreement, including any amendments thereto.
- (c) “Contract Price” means the price payable to the Supplier as specified in the Contract Agreement, subject to such additions and adjustments thereto or deductions there from, as may be made pursuant to the Contract.
- (d) “Day” means calendar day.
- (e) “Completion” means the fulfillment of the supply of Goods to the destination specified and completion of the Related Services by the Supplier in accordance with the terms and conditions set forth in the Contract.
- (f) “CC” means the Conditions of Contract.
- (g) “Goods” means all of the commodities, raw material, machinery and equipment, and/or other materials that the Supplier is required to supply to the Purchaser under the Contract.

- (h) “Purchaser” means the entity purchasing the Goods and Related Services, as specified in the Contract Data.
- (i) “Sub-contractor” means any natural person, private or government entity, or a combination of the above, to whom any part of the Goods to be supplied or execution of any part of the Related Services is subcontracted by the Supplier.
- (j) “Supplier” means the natural person, private or government entity, or a combination of the above, whose bid to perform the Contract has been accepted by the Purchaser and is named as such in the Contract Agreement.
- (k) “The Project Site,” where applicable, means the place named in the Contract Data.
- (l) “The Final Destination” means any port in the Purchaser’s country as specified in the Contract Data.

2. Contract Documents

2.1 Subject to the order of precedence set forth in the Contract Agreement, all documents forming the Contract (and all parts thereof) are intended to be correlative, complementary, and mutually explanatory. The Contract Agreement shall be read as a whole.

3. Fraud and Corruption

3.1 The Government of Sri Lanka requires the Purchaser as well as bidders, suppliers, contractors, and consultants to observe the highest standard of ethics during the procurement and execution of such contracts.
(In pursuit of this policy):

- (i) “Corrupt Practice” means offering, giving, receiving, or soliciting, directly or indirectly, of anything of value to influence the action of a public official in the procurement process or in contract execution;
- (ii) “Fraudulent Practice” means a misrepresentation or omission of facts in order to influence a procurement process or the execution of a contract;
- (iii) “Collusive Practice” means a scheme or arrangement between two or more bidders, with or without the knowledge of the Purchaser to establish bid prices at artificial, non-

competitive levels; and

- (iv) “Coercive Practice” means harming or threatening to harm, directly or indirectly, persons or their property to influence their participation in the procurement process or affect the execution of a contract.

4. Interpretation

4.1 If the context so requires it, singular means plural and vice versa.

4.2 Entire Agreement

The Contract constitutes the entire agreement between the Purchaser and the Supplier and supersedes all communications, negotiations and agreements (whether written or oral) of the parties with respect thereto made prior to the date of Contract.

4.3 Amendment

No amendment or other variation of the Contract shall be valid unless it is in writing, is dated, expressly refers to the Contract, and is signed by a duly authorized representative of each party thereto.

4.4 Severability

If any provision or condition of the Contract is prohibited or rendered invalid or unenforceable, such prohibition, invalidity or unenforceability shall not affect the validity or enforceability of any other provisions and conditions of the Contract.

5. Language

5.1 The Contract as well as all correspondence and documents relating to the Contract exchanged by the Supplier and the Purchaser, shall be written in English language. Supporting documents and printed literature that are part of the Contract may be in another language provided they are accompanied by an accurate translation of the relevant passages in the language specified, in which case, for purposes of interpretation of the Contract, this translation shall govern.

5.2 The Supplier shall bear all costs of translation to the governing language and all risks of the accuracy of such translation, for documents provided by the Supplier.

6. Joint Venture, Consortium or Association

6.1 If the Supplier is a joint venture, consortium, or association, all of the parties shall be jointly and severally liable to the Purchaser for the fulfillment of the provisions of the Contract and shall designate one

party to act as a leader with authority to bind the joint venture, consortium, or association. The composition or the constitution of the joint venture, consortium, or association shall not be altered without the prior consent of the Purchaser.

- 7. Eligibility** 7.1 All goods supplied under this contract shall be complied with applicable standards stipulated or as specified in the Contract Data. In the absence of such standards, the Goods supplied shall be complied with other internationally accepted standards, such as British Standards.
- 8. Notice** 8.1 Any notice given by one party to the other pursuant to the Contract shall be in writing to the address specified in the Contract Data (CC 8.1). The term “in writing” means communicated in written form with proof of receipt.
- 8.2 A notice shall be effective when delivered or on the notice’s effective date, whichever is later.
- 9. Governing Law** 9.1 The Contract shall be governed by and interpreted in accordance with the laws of the Democratic Socialist Republic of Sri Lanka.
- 10. Settlement of Disputes** 10.1 The Purchaser and the Supplier shall make every effort to resolve amicably by direct informal negotiation any disagreement or dispute arising between them under or in connection with the Contract.
- 10.2 If, after twenty-eight (28) days, the parties have failed to resolve their dispute or difference by such mutual consultation, then either the Purchaser or the Supplier may give notice to the other party of its intention to commence arbitration, as hereinafter provided, as to the matter in dispute, and no arbitration in respect of this matter may be commenced unless such notice is given. Any dispute or difference in respect of which a notice of intention to commence arbitration has been given in accordance with this Clause shall be finally settled by arbitration. Arbitration may be commenced prior to or after delivery of the Goods under the Contract. Arbitration proceedings shall be conducted in accordance with the Arbitration Act No:11 of 1995.
- 10.3 Notwithstanding any reference to arbitration herein,
- (a) the parties shall continue to perform their respective obligations under the Contract unless they otherwise agree; and
 - (b) the Purchaser shall pay the Supplier any money due to the Supplier.

- | | | |
|--|------|--|
| 11. Scope of Supply | 11.1 | The Goods and Related Services to be supplied shall be as specified in the Schedule of Requirements. |
| 12. Delivery and Documents | 12.1 | Subject to CC Sub-Clause 32.1, the Delivery of the Goods and Completion of the Related Services shall be in accordance with the Delivery and Completion Schedule specified in the Schedule of Requirements. Where applicable the details of shipping and other documents to be furnished by the Supplier are specified in the Contract Data. |
| 13. Supplier's Responsibilities | 13.1 | The Supplier shall supply all the Goods and Related Services included in the Scope of Supply in accordance with CC Clause 11, and the Delivery and Completion Schedule, as per CC Clause 12. |
| 14. Contract Price | 14.1 | Prices charged by the Supplier for the Goods supplied and the Related Services performed under the Contract shall not vary from the prices quoted by the Supplier in its bid. |
| 15. Terms of Payment | 15.1 | The Contract Price shall be paid as specified in the Contract Data.(CC 15.1) |
| | 15.2 | The Supplier's request for payment shall be made to the Purchaser in writing, accompanied by invoices describing, as appropriate, the Goods delivered and Related Services performed, and by the documents submitted pursuant to CC Clause 12 and upon fulfillment of all other obligations stipulated in the Contract. |
| | 15.3 | Payments shall be made promptly by the Purchaser, but in no case later than twenty eight (28) days after submission of an invoice or request for payment by the Supplier, and after the Purchaser has accepted it. |
| 16. Taxes and Duties | 16.1 | The Supplier shall be entirely responsible for all taxes, duties, license fees, etc., incurred until delivery of the contracted Goods to the Purchaser. |
| 17. Performance Security | 17.1 | If required as specified in the Contract Data (CC 17.1), the Supplier shall, within fourteen (14) days of the notification of contract award, provide a performance security of Ten percent (10%) of the Contract Price for the performance of the Contract. |
| | 17.2 | The proceeds of the Performance Security shall be payable to the Purchaser as compensation for any loss resulting from the Supplier's failure to complete its obligations under the Contract. |
| | 17.3 | As specified in the Contract Data, (CC 17.1) the Performance Security, if required, shall be in Sri Lankan Rupees and shall be in the format stipulated by the Purchaser in Section VIII – Contract Forms, or in another |

format acceptable to the Purchaser.

17.4 The Performance Security shall be discharged by the Purchaser and returned to the Supplier not later than twenty-eight (28) days following the date of Completion of the Supplier's performance obligations under the Contract, including any warranty obligations.

18. Copy Right

18.1 The copyright in all drawings, documents, and other materials containing data and information furnished to the Purchaser by the Supplier herein shall remain vested in the Supplier, or, if they are furnished to the Purchaser directly or through the Supplier by any third party, including suppliers of materials, the copyright in such materials shall remain vested in such third party.

19. Confidential Information

19.1 The Purchaser and the Supplier shall keep confidential and shall not, without the written consent of the other party hereto, divulge to any third party any documents, data, or other information furnished directly or indirectly by the other party hereto in connection with the Contract, whether such information has been furnished prior to, during or following completion or termination of the Contract. Notwithstanding the above, the Supplier may furnish to its Subcontractor such documents, data, and other information it receives from the Purchaser to the extent required for the Subcontractor to perform its work under the Contract, in which event the Supplier shall obtain from such Subcontractor an undertaking of confidentiality similar to that imposed on the Supplier under CC Clause 19.

19.2 The Purchaser shall not use such documents, data, and other information received from the Supplier for any purpose unrelated to the contract. Similarly, the Supplier shall not use such documents, data, and other information received from the Purchaser for any purpose other than the performance of the Contract.

19.3 The above provisions of CC Clause 19 shall not in any way modify any undertaking of confidentiality given by either of the parties hereto prior to the date of the Contract in respect of the Supply or any part thereof.

19.4 The provisions of CC Clause 19 shall survive completion or termination, for whatever reason, of the Contract.

20. Sub-contracting

20.1 The Supplier shall notify the Purchaser in writing of all subcontracts awarded under the Contract if not already specified in the bid. Such notification, in the original bid or later shall not relieve the Supplier from any of its obligations, duties, responsibilities, or liability under the Contract.

- 20.2 Subcontracts shall comply with the provisions of CC Clauses 3 and 7.
- 21. Specifications and Standards**
- 21.1 Technical Specifications and Drawings
- (a) The Goods and Related Services supplied under this Contract shall conform to the technical specifications and standards mentioned in Section V, Schedule of Requirements and, when no applicable standard is mentioned, the standard shall be equivalent or superior to the official standards whose application is appropriate to the Goods' country of origin.
- (b) The Supplier shall be entitled to disclaim responsibility for any design, data, drawing, specification or other document, or any modification thereof provided or designed by or on behalf of the Purchaser, by giving a notice of such disclaimer to the Purchaser.
- (c) Wherever references are made in the Contract to codes and standards in accordance with which it shall be executed, the edition or the revised version of such codes and standards shall be those specified in the Schedule of Requirements. During Contract execution, any changes in any such codes and standards shall be applied only after approval by the Purchaser and shall be treated in accordance with CC Clause 32.
- 22. Packing and Documents**
- 22.1 The Supplier shall pack the Goods as is required to prevent their damage or deterioration during transit to their final destination, as indicated in the Contract Data.
- 23. Insurance**
- 23.1 Unless otherwise specified in the Contract Data, the Goods supplied under the Contract shall be fully insured against loss or damage incidental to manufacture or acquisition, transportation, storage and delivery.
- 24. Transportation**
- 24.1 Unless otherwise specified in the Contract Data, responsibility for arranging transportation of the Goods shall be a responsibility of the supplier.
- 25. Inspections and Tests**
- 25.1 The Supplier shall at its own expense and at no cost to the Purchaser carry out all such tests and/or inspections of the Goods and Related Services as are specified in the

Contract Data (CC 25.1).

- 25.2 The inspections and tests may be conducted on the premises of the Supplier or its Subcontractor, at point of delivery, and/or at the Goods' final destination, or in another place as specified in the Contract Data. Subject to CC Sub-Clause 25.1, if conducted on the premises of the Supplier or its Subcontractor, all reasonable facilities and assistance, including access to drawings and production data, shall be furnished to the inspectors at no charge to the Purchaser.
- 25.3 The Purchaser or its designated representative shall be entitled to attend the tests and/or inspections referred to in CC Sub-Clause 25.2, provided that the Purchaser bear all of its own costs and expenses incurred in connection with such attendance including, but not limited to, all travelling and board and lodging expenses.
- 25.4 Whenever the Supplier is ready to carry out any such test and inspection, it shall give a reasonable advance notice, including the place and time, to the Purchaser. The
- Supplier shall obtain from any relevant third party or manufacturer any necessary permission or consent to enable the Purchaser or its designated representative to attend the test and/or inspection.
- 25.5 The Purchaser may require the Supplier to carry out any test and/or inspection not required by the Contract but deemed necessary to verify that the characteristics and performance of the Goods comply with the technical specifications codes and standards under the Contract, provided that the Supplier's reasonable costs and expenses incurred in the carrying out of such test and/or inspection shall be added to the Contract Price. Further, if such test and/or inspection impedes the progress of manufacturing and/or the Supplier's performance of its other obligations under the Contract, due allowance will be made in respect of the Delivery Dates and Completion Dates and the other obligations so affected.
- 25.6 The Supplier shall provide the Purchaser with a report of the results of any such test and/or inspection.
- 25.7 The Purchaser may reject any Goods or any part thereof that fail to pass any test and/or inspection or do not conform to the specifications. The Supplier shall either rectify or replace such rejected Goods or parts thereof or make alterations necessary to meet the specifications at no cost to the Purchaser, and shall repeat the test and/or inspection, at no cost to the Purchaser, upon giving a notice pursuant to CC Sub-Clause 25.4.

- 25.8 The Supplier agrees that neither the execution of a test and/or inspection of the Goods or any part thereof, nor the attendance by the Purchaser or its representative, nor the issue of any report pursuant to CC Sub-Clause 25.6, shall release the Supplier from any warranties or other obligations under the Contract.
- 25.9 Reports of the tests carried out by the Inspectors must be made available to them immediately after the completion of the tests.
- 26. Liquidated Damages**
- 26.1 Except as provided under CC Clause 31, if the Supplier fails to deliver any or all of the Goods by the Date(s) of delivery or perform the Related Services within the period specified in the Contract, the Purchaser may without prejudice to all its other remedies under the Contract, deduct from the Contract Price, as liquidated damages, a sum equivalent to the percentage specified in the Contract Data of the delivered price of the delayed Goods or unperformed Services for each week or part thereof of delay until actual delivery or performance, up to a maximum deduction of the percentage specified in those Contract Data CC 26.1. Once the maximum is reached, the Purchaser may terminate the Contract pursuant to CC Clause 34.
- 27. Warranty**
- 27.1 The Supplier warrants that all the Goods are new, unused, and of the most recent or current models, and that they incorporate all recent improvements in design and materials, unless provided otherwise in the Contract.
- 27.2 Subject to CC Sub-Clause 21.1(b), the Supplier further warrants that the Goods shall be free from defects arising from any act or omission of the Supplier or arising from design, materials, and workmanship, under normal use in the conditions prevailing in the country of final destination.
- 27.3 Unless otherwise specified in the Contract Data CC 27.3, the warranty shall remain valid for twelve (12) months after the Goods, or any portion thereof as the case may be, have been delivered to and accepted at the final destination indicated in the Contract Data CC 8.1.
- 27.4 The Purchaser shall give notice to the Supplier stating the nature of any such defects together with all available evidence thereof, promptly following the discovery thereof. The Purchaser shall afford all reasonable opportunity for the Supplier to inspect such defects.
- 27.5 Upon receipt of such notice, the Supplier shall, within the period specified in the Contract Data CC 27.5,

expeditiously repair or replace the defective Goods or parts thereof, at no cost to the Purchaser.

27.6 If having been notified, the Supplier fails to remedy the defect within the period specified in the Contract Data CC 27.5 the Purchaser may proceed to take within a reasonable period such remedial action as may be necessary, at the Supplier's risk and expense and without prejudice to any other rights which the Purchaser may have against the Supplier under the Contract.

28. Patent Indemnity

28.1 The Supplier shall, subject to the Purchaser's compliance with CC Sub-Clause 28.2, indemnify and hold harmless the Purchaser and its employees and officers from and against any and all suits, actions or administrative proceedings, claims, demands, losses, damages, costs, and expenses of any nature, including attorney's fees and expenses, which the Purchaser may suffer as a result of any infringement or alleged infringement of any patent, utility model, registered design, trademark, copyright, or other intellectual property right registered or otherwise existing at the date of the Contract by reason of :

- (a) the installation of the Goods by the Supplier or the use of the Goods in the country where the Site is located; and
- (b) The sale in any country of the products produced by the Goods.

Such indemnity shall not cover any use of the Goods or any part thereof other than for the purpose indicated by or to be reasonably inferred from the Contract, neither any infringement resulting from the use of the Goods or any part thereof, or any products produced thereby in association or combination with any other equipment, plant, or materials not supplied by the Supplier, pursuant to the Contract.

28.2 If any proceedings are brought or any claim is made against the Purchaser arising out of the matters referred to in CC Sub-Clause 28.1, the Purchaser shall promptly give the Supplier a notice thereof, and the Supplier may at its own expense and in the Purchaser's name conduct such proceedings or claim and any negotiations for the settlement of any such proceedings or claim.

28.3 If the Supplier fails to notify the Purchaser within twenty-eight (28) days after receipt of such notice that it intends to conduct any such proceedings or claim, then the Purchaser shall be free to conduct the same on its own behalf.

28.4 The Purchaser shall, at the Supplier's request, afford all available assistance to the Supplier in conducting such

proceedings or claim, and shall be reimbursed by the Supplier for all reasonable expenses incurred in so doing.

28.5 The Purchaser shall indemnify and hold harmless the Supplier and its employees, officers, and Subcontractors from and against any and all suits, actions or administrative proceedings, claims, demands, losses, damages, costs, and expenses of any nature, including attorney's fees and expenses, which the Supplier may suffer as a result of any infringement or alleged infringement of any patent, utility model, registered design, trademark, copyright, or other intellectual property right registered or otherwise existing at the date of the Contract arising out of or in connection with any design, data, drawing, specification, or other documents or materials provided or designed by or on behalf of the Purchaser.

29. Limitation of Liability

29.1 Except in cases of criminal negligence or willful misconduct,

(a) the Supplier shall not be liable to the Purchaser, whether in contract, tort, or otherwise, for any indirect or consequential loss or damage, loss of use, loss of production, or loss of profits or interest costs, provided that this exclusion shall not apply to any obligation of the Supplier to pay liquidated damages to the Purchaser and

(b) the aggregate liability of the Supplier to the Purchaser, whether under the Contract, in tort or otherwise, shall not exceed the total Contract Price, provided that this limitation shall not apply to the cost of repairing or replacing defective equipment, or to any obligation of the supplier to indemnify the purchaser with respect to patent infringement.

30. Change in Laws and Regulations

30.1 Unless otherwise specified in the Contract, if after the date of 28 days prior to date of Bid submission, any law, regulation, ordinance, order or bylaw having the force of law is enacted, promulgated, abrogated, or changed in Sri Lanka that subsequently affects the Delivery Date and/or the Contract Price, then such Delivery Date and/or Contract Price shall be correspondingly increased or decreased, to the extent that the Supplier has thereby been affected in the performance of any of its obligations under the Contract. Notwithstanding the foregoing, such additional or reduced cost shall not be separately paid or credited if the same has already been accounted for in the price adjustment provisions where applicable, in accordance with CC Clause 14.

- 31. Force Majeure**
- 31.1 The Supplier shall not be liable for forfeiture of its Performance Security, liquidated damages, or termination for default if and to the extent that its delay in performance or other failure to perform its obligations under the Contract is the result of an event of Force Majeure.
- 31.2 For purposes of this Clause, “Force Majeure” means an event or situation beyond the control of the Supplier that is not foreseeable, is unavoidable, and its origin is not due to negligence or lack of care on the part of the Supplier. Such events may include, but not be limited to, acts of the Purchaser in its sovereign capacity, wars or revolutions, fires, floods, epidemics, quarantine restrictions, and freight embargoes.
- 31.3 If a Force Majeure situation arises, the Supplier shall promptly notify the Purchaser in writing of such condition and the cause thereof. Unless otherwise directed by the Purchaser in writing, the Supplier shall continue to perform its obligations under the Contract as far as is reasonably practical, and shall seek all reasonable alternative means for performance not prevented by the Force Majeure event.
- 32. Change Orders and Contract Amendments**
- 32.1 The Purchaser may at any time order the Supplier through notice in accordance CC Clause 8, to make changes within the general scope of the Contract in any one or more of the following:
- (a) drawings, designs, or specifications, where Goods to be furnished under the Contract are to be specifically manufactured for the Purchaser;
 - (b) the method of shipment or packing;
 - (c) the place of delivery; and
 - (d) The Related Services to be provided by the Supplier.
- 32.2 If any such change causes an increase or decrease in the cost of, or the time required for, the Supplier’s performance of any provisions under the Contract, an equitable adjustment shall be made in the Contract Price or in the Delivery/Completion Schedule, or both, and the Contract shall accordingly be amended. Any claims by the Supplier for adjustment under this Clause must be asserted within twenty-eight (28) days from the date of the Supplier’s receipt of the Purchaser’s change order.
- 32.3 Prices to be charged by the Supplier for any Related Services that might be needed but which were not included

in the Contract shall be agreed upon in advance by the parties and shall not exceed the prevailing rates charged to other parties by the Supplier for similar services.

32.4 Subject to the above, no variation in or modification of the terms of the Contract shall be made except by written amendment signed by the parties.

33. Extensions of Time

33.1 If at any time during performance of the Contract, the Supplier or its subcontractors should encounter conditions impeding timely delivery of the Goods or completion of Related Services pursuant to CC Clause 12, the Supplier shall promptly notify the Purchaser in writing of the delay, its likely duration, and its cause. As soon as practicable after receipt of the Supplier's notice, the Purchaser shall evaluate the situation and may at its discretion extend the Supplier's time for performance, in which case the extension shall be ratified by the parties by amendment of the Contract.

33.2 Except in case of Force Majeure, as provided under CC Clause 31, a delay by the Supplier in the performance of its Delivery and Completion obligations shall render the Supplier liable to the imposition of liquidated damages pursuant to CC Clause 26, unless an extension of time is agreed upon, pursuant to CC Sub-Clause 33.1.

34. Termination

34.1 Termination for Default

(a) The Purchaser, without prejudice to any other remedy for breach of Contract, by written notice of default sent to the Supplier, may terminate the Contract in whole or in part:

(i) if the Supplier fails to deliver any or all of the Goods within the period specified in the Contract, or within any extension thereof granted by the Purchaser pursuant to CC Clause 33;

(ii) if the Supplier fails to perform any other obligation under the Contract; or

(iii) If the Supplier, in the judgment of the Purchaser has engaged in fraud and corruption, as defined in CC Clause 3, in competing for or in executing the Contract.

In the event the Purchaser terminates the Contract in

whole or in part, pursuant to CC Clause 34.1(a), the Purchaser may procure, upon such terms and in such manner as it deems appropriate, Goods or Related Services similar to those undelivered or not performed, and the Supplier shall be liable to the Purchaser for any additional costs for such similar Goods or Related Services. However, the Supplier shall continue performance of the Contract to the extent not terminated.

34.2 Termination for Insolvency.

- (a) The Purchaser may at any time terminate the Contract by giving notice to the Supplier if the Supplier becomes bankrupt or otherwise insolvent. In such event, termination will be without compensation to the Supplier, provided that such termination will not prejudice or affect any right of action or remedy that has accrued or will accrue thereafter to the Purchaser.

34.3 Termination for Convenience.

- (a) The Purchaser, by notice sent to the Supplier, may terminate the Contract, in whole or in part, at any time for its convenience. The notice of termination shall specify that termination is for the Purchaser's convenience, the extent to which performance of the Supplier under the Contract is terminated, and the date upon which such termination becomes effective.
- (b) The Goods that are complete and ready for shipment within twenty-eight (28) days after the Supplier's receipt of notice of termination shall be accepted by the Purchaser at the Contract terms and prices. For the remaining Goods, the Purchaser may elect:
 - (i) to have any portion completed and delivered at the Contract terms and prices; and/or
 - (ii) To cancel the remainder and pay to the Supplier an agreed amount for partially completed Goods and Related Services and for materials and parts previously procured by the Supplier.

35. Assignment

- 35.1 Neither the Purchaser nor the Supplier shall assign, in whole or in parts their obligations under this Contract, except with prior written consent of the other

party.

36. Country of Origin

The country of origin shall be clearly stated by the bidder for the items to be purchased in the offer.
Contract Data CC 36.

SECTION –VIII
CONTRACT FORMS

CONTENTS

PAGE

- | | |
|---|--------------|
| 1. Contract Agreement | 37-38 |
| 2. Format for Performance Guarantee | 39 |
| 3. Format for Release of Retention Money | 40 |

1. Contract Agreement

THIS CONTRACT AGREEMENT is made

the [*insert : Number*] day of [*insert : month*], [*insert: Year*]

BETWEEN

(1) [*insert complete name of Purchaser*], a [*insert description of type of legal entity, for example, an agency of the Ministry of*
..... *or corporation*] and having its principal place of business at [*insert address of purchaser*] (hereinafter called “the Purchaser”) and

(2) [*insert name of Supplier*], a corporation incorporated under the laws of [*insert : country of Supplier*] and having its principal place of business at [*insert : address of supplier*] hereinafter called “the Supplier”).

WHEREAS the Purchaser invited bids for certain Goods and ancillary service, viz., [*insert brief description of Goods and Service*] and has accepted a Bid by the Supplier for the supply of those Goods and Services in the sum of [*insert Contract Price in words and figures, expressed in the Contract currency (ies)*] (hereinafter called “the Contract Price”)

NOW THIS AGREEMENT WITNESS AS FOLLOWS:

1. In this Agreement words and expressions shall have the same meanings as are respectively assigned to them in the Conditions of Contract referred to.

2. The following documents shall constitute the Contract between the **Purchaser** and the Supplier, and each shall be read and constructed as an integral part of the Contract:

- (a) This Contract Agreement ;
- (b) Contract Data;
- (c) Conditions of Contract;
- (d) Technical Requirements (including Schedule of Requirements and Technical Specifications);
- (e) The Supplier’s Bid and original Price Schedules;
- (f) The Purchaser’s Notification of Award.
- (g) The supplier’s acknowledgement
- (h) [*Add here any other document (s)*].

3. This contract shall prevail over all other Contract documents. In the event of any discrepancy or inconsistency within the Contract documents., then the documents shall prevail in the order listed above.

4. In consideration of the payments to be made by the Purchaser to the Suppliers as hereinafter mentioned, the Supplier hereby covenants with the Purchaser to provide the Goods and Services and to remedy defects there in conformity in all respects with the provisions of the Contract.

5. The Purchaser hereby covenants to pay the Supplier in consideration of the provision of the Goods and Services and the remedying of defects therein, the Contract Price or such other sum as may become payable under the provisions of the Contract at the times and in the manner prescribed by the Contract.

IN WITNESS whereof the parties hereto have caused this Agreement to be executed in accordance with the laws of *Democratic Socialist Republic of Sri Lanka* on the day, month and year indicated above.

For and on behalf of the Purchaser

Signed : *[insert signature]*

In the capacity of *[insert title or other appropriate designation]*

In the presence of *[insert identification of official witness]*

For and on behalf of the Supplier.

Signed : *[insert signature of authorized representative (s) of the Supplier]*

In the capacity of *[insert title or other appropriate designation]*

In the presence of *[insert identification of official witness]*

2. FORMAT FOR PERFORMANCE GUARANTEE

(PROCUREMENT GUIDELINE REFERENCE 5.4.8)

.....(*Issuing Agency’s Name, and Address of Issuing Branch or Office*)

.....

Beneficiary : (*Name and Address of Employer*)
.....

Date :

PERFORMANCE GUARANTEE No. :

We have been informed that (*name of Contractor/Supplier*)
(**hereinafter called “the Contractor”**) has entered into Contract No.
..... (*reference number of the contract*) dated
..... with you, for the (*insert “construction” / “Supply”*) of (*name of contract and brief description of Works / (hereinafter called “the Contract”*).

Furthermore, we understand that, according to the conditions of the Contract, a performance guarantee is required.

At the request of the **Contractor**, we (*name of Agency*) hereby irrevocably undertake to pay you any sum or sums not exceeding in total an amount of (*amount in figures*)
(.....) (*amount in words*) / such sum being payable in the types and proportion of currencies in which the Contract Price is payable, upon receipt by us of your first demand in writing accompanied by a written statement stating that the Contractor is in breach of its obligation(s) under the Contract, without your needing to prove or to show grounds for your demand or the sum specified therein.

This guarantee shall expire, no later than the day of 20..... (*insert date, 28 days beyond the scheduled contract completion date*) and any demand for payment under it must be received by us at this office on or before that date.

.....
(Signature(s))

3. FORMAT FOR RELEASE OF RETENTION MONEY

(PROCUREMENT GUIDELINE REFERENCE 5.4.7)

.....(Issuing Agency's Name, and Address of Issuing Branch or Office)

.....

Beneficiary: (Name and Address of Employer)

.....

Date :

RETENTION MONEY GUARANTEE No:

We have been informed that (name of Contractor) (**hereinafter called** “the Contractor”) has entered into Contract No. (reference number of the contract) dated with you, for the execution of (name of contract and brief description of Works / (**hereinafter called** “the Contract”).

Furthermore, we understand that, according to the conditions of the Contract, when the works have being taken over and the first half of the Retention Money has been certified for payment, payment of the second half of the Retention Money may be made against a Retention Money guarantee.

At the request of the Contractor, we (name of Bank) hereby irrevocably undertake to pay you any sum or sums not exceeding in total an amount of (amount in figures) (.....) (amount in words) / upon receipt by us of your first demand in writing accompanied by a written statement stating that the Contractor is in breach of its obligation under the Contract because the Contractor has not attended to the defects in accordance with the Contract.

This guarantee shall expire, at the latest, (insert 28 days after the end of the defects liability period). Consequently, any demand for payment under this guarantee must be received by us at this office on or before that date.

.....
Signature(s)

**PROCUREMENT OF 45,000 NOS. HIGH FRICTION COMPOSITE BRAKE
BLOCKS**

INTERNATIONAL COMPETITIVE BIDDING DOCUMENT

VOLUME 1

SECTION -I	INSTRUCTION TO BIDDERS (ITB)
SECTION -VI	CONDITIONS OF CONTRACT (CC)
SECTION -VIII	CONTRACT FORMS

VOLUME 2

SECTION II	BIDDING DATA SHEET (BDS)
SECTION III	EVALUATION AND QUALIFYING CRETERIA
SECTION IV	BIDDING FORMS
SECTION V	SCHEDULE OF REQUIREMENTS
SECTION VII	CONTRACT DATA
INVITATION FOR BIDS	

**Department Procurement Committee (Major),
Sri Lanka Railways,
Olcott Mawatha,
Colombo 10,
Sri Lanka.**

CONTENTS	PAGE
SECTION -II BIDDING DATA SHEET	43-46
SECTION -III EVALUATION AND QUALIFYING CRITERIA	47-48
SECTION -IV BIDDING FORMS	49-57
SECTION -V SCHEDULE OF REQUIREMENTS	58-65
SECTION -VII CONTRACT DATA	66-73
INVITAION FOR BIDS	74-75
LIST OF FOREIGN MISSION ABROAD	76

SECTION - II

BIDDING DATA SHEET

Section II. Bidding Data Sheet (BDS)

The following specific data for the goods to be procured shall complement, supplement, or amend the provisions in the Instructions to Bidders (ITB). Whenever there is a conflict, the provisions herein shall prevail over those in ITB.

ITB Clause Reference	A. General
ITB 1.1	The Purchaser is: Sri Lanka Railways
ITB 1.1	<p style="text-align: center;">The name and identification number of the Contract are: PROCUREMENT OF 45,000 NOS. HIGH FRICTION COMPOSITE BRAKE BLOCKS</p> <p>IFB No- SRS/F.8017</p>
ITB 2.1	The source of funding is: Consolidated fund - Government of Sri Lanka (GOSL)
ITB 4.1	<p>The manufacturer of the item shall have experience of more than five (05) years in manufacturing and supplying High Friction Composite Brake Blocks.</p> <p>The Manufacturer of the item shall have completed at least three (03) bulk orders of the item during last three (03) years and one out of which shall be to a Railway organization outside the country of the manufacture. Performance certificates/end user certificates shall also be provided along with the bid.</p>
ITB 4.4	Foreign bidders may submit bids.
ITB 5.1	Brake Blocks to be supplied shall be complied SLR Specification.
	B. Contents of Bidding Documents
ITB 7.1	<p>For Clarification of bid purposes only, the Purchaser's address is:</p> <p>Attention: Deputy General Manager (Procurement), Address: Railway Procurement Sub Department, P.O. Box 1347, Olcott Mawatha, Colombo, Sri Lanka.</p> <p>Telephone: 94 (11) 2438078 or 94(11) 4600202</p> <p>Facsimile number: 94(11) 2432044</p> <p>Electronic mail address: srs.slr@gmail.com, tender1@railway.gov.lk</p> <p>A prospective bidder requiring any clarification of the bidding documents may notify the Purchaser in writing, by Fax or E-mail at the Purchaser's address given above.</p>

C. Preparation of Bids	
ITB 11.1 (f)	<p>The Bidder shall submit the following documents:</p> <ol style="list-style-type: none"> 1. Official Bid Document. 2. Legally executed Power of Attorney (where applicable) as per Cl.- 45 of ITB of BDS. 3. Certificate of Registration with the Registrar of Contracts as per Cl.- 46 of ITB of BDS. 4. Quality Management System Standard certificate for the manufacturing and supplying of composite brake blocks as per – Cl.- 7.1 of the Contract Data. 5. Certificate of performance supplying similar goods as per the post qualification criteria as per Cl. 7.1 of the Contract Data. 6. Period of Supplier’s Warranty and Statement as per Cl. –27of CC and Contract Data. 7. Period of Delivery as per Cl. 12 of CC and Contract Data. 8. Supplier’s Specification as per Cl. - 3.(i) 9. Supplier’s Drawing and Design Quality Standard as per technical specification. 10. Duly perfected and signed Compliance sheet. 11. Test certificates as per technical specification 12. Any other applicable document such as Technical Support provided by the Supplier. 13. Details of packaging. 14. Details of Local Agent as per Cl. – 44 of ITB of BDS.
ITB 14.1	Total bid price of the goods shall be FOB and CIF price Colombo Port
ITB 14.4	Not applicable. The term CIF Colombo Port shall be governed by the rules prescribed in the current edition of Inco-terms, published by the International Chamber of Commerce,
ITB 15.1	The bidder shall quote in the freely convertible currency in which the payment is required. For evaluation purposes the price shall be converted to Sri Lankan rupees and the exchange rate published by the Central Bank of Sri Lanka 28 days prior to closing of bids shall be considered for the conversion.
ITB 18.1 (b)	After sales service is: “not required”
ITB 19.1	The bid shall be valid until 22/05/2025
ITB 20.1	Bid shall include a Bid Security issued by a local bank operating in Sri Lanka and approved by Central Bank of Sri Lanka included in

	<p>Section IV Bidding Forms;</p> <p>The bidder shall submit the bid security in the prescribed format in the Section IV – Bidding Forms. Submission of bid security with any major departure from the prescribed format shall be considered as major deviation and particular bid shall be rejected.</p>
ITB 20.2	<p>The amount of the Bid Security shall be LKR. 3,800,000.00 or equivalent in convertible currency. The exchange rate published by the Central Bank of Sri Lanka 28 days prior to the closing of bids shall be considered for the conversion.</p> <p>The validity period of the bid security shall be until 21/06/2025 (150 days from the date of bid opening)</p>
	D. Submission and Opening of Bids
ITB 22.2 (c)	<p>The inner and outer envelopes shall bear the following identification marks: SRS / F.8017</p> <p>(a) Bear the Name and Address of the Bidder. (b) be addressed as indicated in Cl. 23.1 of ITB. (c) bear the specific identification of this bidding process as indicated in ITB 1.1 of BDS. (d) Make on both envelopes “ Do not open before 2.00 p.m. on 22/01/2025 ”. (Bid opening date)</p>
ITB 23.1	<p>Bids shall be submitted to:</p> <p>Attention: The Chairman, Address: Department Procurement Committee (Major) Sri Lanka Railways, Railway Procurement Sub Department, Olcott Mawatha, Colombo 10, Sri Lanka</p> <p>The deadline for the submission of bids is: Date: 22/01/2025 Time: 2.00 p.m.</p>
ITB 26.1	<p>The bid opening shall take place at:</p> <p>Address: 3rd floor, room number 1 Railway Procurement Sub Department, No. 1347, Olcott Mawatha, Colombo 10 Sri Lanka</p> <p>Date: 22/01/2025 Time: 2.00 p.m.</p>
	E. Evaluation and Comparison of Bids
ITB 35.5	Domestic preference shall not be a bid evaluation factor
	F .Award of Contract

SECTION –III
EVALUATION AND QUALIFYING CRITERIA

Section III. Evaluation and Qualification Criteria

This Section complements the Instructions to Bidders. It contains the criteria that the Purchaser use to evaluate a bid and determine whether a Bidder has the required qualifications. No other criteria shall be used.

1. Post qualification Requirements (ITB 37.2)

After determining the lowest-evaluated bid in accordance with ITB Sub-Clause 36.1, the Purchaser shall carry out the post qualification of the Bidder in accordance with ITB Clause 37, using only the requirements specified. Requirements indicated below shall be used in the evaluation of the Bidder's qualifications.

(a) Financial Capability

The Bidder shall furnish documentary evidence that it meets the following financial requirement(s):

The Bidder shall submit Audited Annual Turnover for the last 5 years and the net worth shall be positive.

(b) Experience and Technical Capacity.

The Bidder shall furnish documentary evidence to demonstrate that it meets the requirement and experience mentioned below.

- i. The manufacturer of the item shall submit the documentary evidence to prove the potential and experience in manufacturing and supplying High Friction Composite Brake Blocks for the use of air brake operated Railway coaches by providing at least three (3) Nos. duly completed purchase orders per annum for the last 5 years for similar supplies.
- ii. The manufacturer of the item shall have completed at least three (03) bulk orders of the item during last three (03) years and one out of them shall be supplied to a Railway organization outside the country of the manufacture.
- iii. Manufacturer shall provide at least five (05) end user certificates/Performance certificate for already sold High Friction Brake Blocks for orders completed within last five (05) years up to the date of bid submission. Out of that, one should be outside the country of manufacturer,

(d) Bid shall be evaluated on FOB price.

Bids shall be evaluated based on the FOB Prices quoted by the Bidders.

Section IV. Bidding Forms

Table of Forms

Bid Submission Form.....	50 - 52
Price Schedule:.....	53 - 54
Bid Security (Guarantee)	56
Manufacturer's Authorization	57

Bid Submission Form

Date: *[insert date (day, month and year) of Bid Submission]*
No.: *[insert number of bidding process]*

To: Chairperson,
Standing Cabinet Appointed Procurement Committee

We, the undersigned, declare that:

- (a) We have examined and have no reservations to the Bidding Documents, including Addenda No.:
[insert the number and issuing date of each Addenda];
- (b) We offer to supply in conformity with the Bidding Documents and in accordance with the Delivery Schedules specified in the Schedule of Requirements the following Goods and Related Services
[insert a brief description of the Goods and Related Services];*
- (c) The total price of our Bid, including any discounts offered is:
[insert the total bid price in words and figures];
- (d) Our bid shall be valid for the period of time specified in ITB Sub-Clause 19.1, from the date fixed for the bid submission deadline in accordance with ITB Sub-Clause 23.1, and it shall remain binding upon us and may be accepted at any time before the expiration of that period;
- (e) If our bid is accepted, we commit to obtain a performance security in accordance with ITB Clause 43 and CC Clause 17 for the due performance of the Contract;
- (f) We have no conflict of interest in accordance with ITB Sub-Clause 4.3;
- (g) Our firm, its affiliates or subsidiaries - including any subcontractors or suppliers for any part of the contract - has not been declared blacklisted by Department of Public Finance.
- (k) We understand that this bid, together with your written acceptance thereof included in your notification of award, shall constitute a binding contract between us, until a formal contract is prepared and executed.
- (l) We understand that you are not bound to accept the lowest evaluated bid or any other bid that you may receive.

I/We submit the following documents as part of my/our bid as per ITB 11.1e of BDS.

- 1. Official Bidding Document.
- 2. Legally executed Power of Attorney (where applicable as per C1 45 of ITB of BDS.
- 3. Certificate of Registration of Contract as per C1.46 of ITB of BDS
- 4. Quality Management System Standard Certificate for the manufacture of high friction composite brake blocks as per C1. 7.1 of the Contract Data.

5. Certificate of performance supplying similar goods as per the post qualification criteria as per CI 7.1 of Contract Data.
6. Period of Supplier's Warranty and Statement as per CI.-27 of CC and Contract data.
7. Period of Delivery as per CI 12 of CC and Contract Data.
8. Supplier's Specification
9. Supplier's Drawing and Design Quality Standard as per Clause – 3 (ii)
10. Test Certificates of the Technical Specification.
11. Any other applicable document such as.
 - a) Schedule of Price – Duly completed and signed
 - b) Bid Security Guarantee as per C1 20 of BDS
 - c) Manufacturer's Authorization
 - d) Brochures
 - e) Details of packaging
12. My/Our Bank reference is as follows:

Date:

.....
Signature of Bidder

Name of Bidder:

Postal Address:

.....

Email Address:

Telephone Number:

Fax:

Details of the Local Agent, if any:

Name:

Postal Address:

.....

The year of registration of the business of the local agent.....

Amount to be paid to the Local Agent as their Commission, which shall be included in the total FOB price:

Email Address:

Telephone Number:

Fax:

PRICE SCHEDULE

Currencies in accordance with ITB Sub Clause 15

1	2	3	4	5	6	7	8	9	10	
Line Item N°	Description of Goods	Country of Origin as per Cl. 36 of CC	Quantity and Physical Unit	Unit Price per brake block FOB	Total FOB Price 4 x 5	Freight Charges in Ceylon Shipping Corporation Vessels	Freight Charges in other Vessels	Cost of Insurance	Total CIF Value	
									In Ceylon Shipping Corporation Vessels =6+7+9	In other Vessels =6+8+9
1.	High Friction Composite Brake Blocks		45,000 Nos.							

1. Total FOB, Freight and Insurance and CIF prices shall be furnished
2. Whether price reduction / discount is applicable. In event of Bidders offering price reduction / discount, they should indicate the total reduced price for each item on FOB and CIF in addition to the normal price quoted.
3. Name and Address of the Local Agent
.....
Phone: Fax: e-mail:
4. Percentage of the Commission payable to the Local Agent: Commission shall be included in FOB price.
5. Port of Loading

Date.....

.....
Bidder's Signature

Local Supply
Schedule of Price and Bill of Quantities for the Supply of 45,000 Nos. High Friction Composite Brake Blocks
Procurement No. SRS/F. 8017

Item No.	Description	Quantity		Unit Price without VAT (Rs.)	Total Price (Rs.)	18% VAT	Total Price with VAT (Rs.)
01	High Friction Composite Brake Blocks	45,000	In Figures				
			In words				

Bid Security Guarantee

Bid Security Guarantee

[this Bank Guarantee form shall be filled in accordance with the instructions indicated in brackets]

----- *[insert issuing agency's name, and address of issuing branch or office]* -----

***Beneficiary:** General Manger Sri Lanka Railways

Date: ----- *[insert (by issuing agency) date]*

BID GUARANTEE No.: ----- *[insert (by issuing agency) number]*

We have been informed that ----- *[insert (by issuing agency) name of the Bidder; if a joint venture, list complete legal names of partners]* (hereinafter called "the Bidder") has submitted to you its bid dated ----- *[insert (by issuing agency) date]* (hereinafter called "the Bid") for the supply of *[insert name of Supplier]* under Invitation for Bids No. ----- *[insert IFB number]* ("the IFB").

Furthermore, we understand that, according to your conditions, Bids must be supported by a Bid Guarantee.

At the request of the Bidder, we ----- *[insert name of issuing agency]* hereby irrevocably undertake to pay you any sum or sums not exceeding in total an amount of ----- *[insert amount in figures]* ----- *[insert amount in words]*) upon receipt by us of your first demand in writing accompanied by a written statement stating that the Bidder is in breach of its obligation(s) under the bid conditions, because the Bidder:

- (a) has withdrawn its Bid during the period of bid validity specified; or
- (b) does not accept the correction of errors in accordance with the Instructions to Bidders (hereinafter "the ITB"); or
- (c) having been notified of the acceptance of its Bid by the Purchaser during the period of bid validity, (i) fails or refuses to execute the Contract Form, if required, or (ii) fails or refuses to furnish the Performance Security, in accordance with the ITB.

This Guarantee shall expire: (a) if the Bidder is the successful bidder, upon our receipt of copies of the Contract signed by the Bidder and of the Performance Security issued to you by the Bidder; or (b) if the Bidder is not the successful bidder, upon the earlier of (i) our receipt of a copy of your notification to the Bidder that the Bidder was unsuccessful, otherwise it will remain in force up to ----- *(insert date)*

Consequently, any demand for payment under this Guarantee must be received by us at the office on or before that date. _____

[signature(s) of authorized representative(s)]

Manufacturer's Authorization

[The Bidder shall require the Manufacturer to fill in this Form in accordance with the instructions indicated. This letter of authorization should be on the letterhead of the Manufacturer and should be signed by a person with the proper authority to sign documents that are binding on the Manufacturer. The Bidder shall include it in its bid, if so indicated in the BDS.]

Date: *[insert date (as day, month and year) of Bid Submission]*
No.: *[insert number of bidding process]*

To: *[insert complete name of Purchaser]*

WHEREAS

We *[insert complete name of Manufacturer]*, who are official manufacturers of *[insert type of goods manufactured]*, having factories at *[insert full address of Manufacturer's factories]*, do hereby authorize *[insert complete name of Bidder]* to submit a bid the purpose of which is to provide the following Goods, manufactured by us *[insert name and or brief description of the Goods]*, and to subsequently negotiate and sign the Contract.

We hereby extend our full guarantee and warranty in accordance with Clause 27 of the Conditions of Contract, with respect to the Goods offered by the above firm.

Signed: *[insert signature(s) of authorized representative(s) of the Manufacturer]*

Name: *[insert complete name(s) of authorized representative(s) of the Manufacturer]*

Title: *[insert title]*

Duly authorized to sign this Authorization on behalf of: *[insert complete name of Bidder]*

Dated on _____ day of _____, _____ *[insert date of signing]*

Section V.
Schedule of Requirements

Contents

	Page No
1. List of Goods and Delivery Schedule.....	60
2. Technical Specifications.....	61-64
3.. Drawings.....	65

List of Goods and Delivery Schedule

1	Description of Goods	High Friction Composite Brake Blocks
2	Quantity	45,000 Nos.
3	Standards	The goods supplied under this contract shall conform to SLR specification issued with the bid. The bidder shall submit the specifications in detail of the materials offered by them and in lieu of same, statements issued by the bidders agreeing to comply with SLR specification will not be accepted.
4	Packing	These blocks shall be packed in suitably strong containers to withstand rough handling, long sea voyage and storage in the open area packing shall permit easy forklift of crane handling.
5	Delivery and Completion	<p>A) Foreign suppliers shall deliver the goods as follows. First batch (15,000 Nos.) - Fourteen (14) weeks from the date of opening of L/C. Second batch (15,000 Nos.) - Thirty (30) weeks from the date of opening of L/C. Third batch (15,000 Nos.) – Forty five (45) weeks from the date of opening of L/C. The supplier shall forward copies of the documents as per CC 12.1 in duplicate to the purchaser by courier service immediately on shipment of goods.</p> <p>B) In case of a local supplier (Import and supply basis) The Local supplier shall deliver the goods to Rathmalana stores, Sri Lanka Railways as follows First batch (15,000 Nos.) - Fourteen (14) weeks from the date of placing the order. Second batch (15,000 Nos.) - Thirty (30) weeks from the date of placing the order. Third batch (15,000 Nos.) - Forty five (45) weeks from the date of placing the order.</p>

No.	Description of Goods	Quantity	Unit	Final Destination as specified in BDS	Delivery Date	
					Required Date of Delivery (Shipping)	Bidder's offered Delivery Date
1	High Friction Composite Brake Blocks	45,000 Nos.	Number	Colombo-Port Sri Lanka	First batch (15,000 Nos.) - Fourteen (14) weeks from the date of opening of L/C. Second batch (15,000 Nos.) - Thirty (30) weeks from the date of opening of L/C. Third batch (15,000 Nos.) – Forty five (45) weeks from the date of opening of L/C.	

2. TECHNICAL SPECIFICATIONS

SRI LANKA RAILWAY TECHNICAL SPECIFICATION FOR HIGH FRICTION COMPOSITE BRAKE BLOCKS TO SRI LANKA RAILWAYS

1. SCOPE

This specification provide for the design manufacture, supply and delivery of High Friction Non Metallic composite Brake Blocks to be used on Diesel Multiple Units (S8,S9,S10,S11,S12,S13,S14) and Locomotives (M9) which are operating on compressed air brake system with high friction composite brake blocks. Drawing No. S 2678/03, Store No. RMS 78/73/02

2. GENERAL

The brake blocks required shall be in accordance with SLR drawing No. S 2678/03 and shall have limiting dimensions of 280mm \pm 5mm chordal length, 90mm \pm 3mm width and 48mm \pm 3mm thickness at the center. The brake blocks should properly fit holders to SLR drawing No. P 4006/00 and are intended for use on 914mm diameter wheels. However, the blocks shall be suitable for approximately 850mm to 950mm wheels. A manufacturer's completed drawing of the offered brake blocks shall be submitted with the bid.

3. MATERIAL CONSTRUCTION AND FRICTIONAL CHARACTERISTICS

1. The brake blocks shall have metal backing plates with rolled edges, solid tunnel type hasps raised central lump to take the brake thrust. The metal back plates shall be sufficient strength and design which ensures adequate keying of the composite friction material to prevent cracking or separation of the block at any stage of wear to the condemning limit.
2. The composite brake blocks shall be suitable for used on vehicles which were designed for compressed air brake systems. Full braking in wet conditions should not result in wheel slide at unloaded vehicles. Tare weight of a coach is approximately 35 MT.
3. For a shoe load of 18 kN for compressed air system and on axle load of 16.5Ton the average value of coefficient of friction between the wheel and the brake block shall be 0.3.
4. The effect of temperature change due to service operating conditions up to 100 km/h on the frictional value of the brake blocks shall be such that no appreciable reduction in braking power is dissemble.
5. The bidder shall conduct dynamometer test to confirm the brake force obtained and shall provide with the tender documents, data and graphs, which detail the average coefficient of friction under all conditions nominated. The bidder shall provide graphs showing variations of average coefficient of friction against the wheel speed (kmph) the maximum train speed is 100 kmph.
6. The brake blocks shall not produce grooving, thermal tracks, shelling, excessive wear or other detrimental effects to type surfaces. Any defect noticed during field test in SLR with samples shall be considered in bid evaluation.
7. Average wear ratio of the block (mm/1000 km) must be an accepted value. Average wear rate shall be tested in the field test at SLR and consider for bid evaluation.

4. MATERIAL SPECIFICATION

1. The material shall have acceptable brake life. High Friction stability, good wheel conditioning and reduce fade in heavy duty application.
2. Absolutely no asbestos shall be used and only natural cellulose or harmless organic fibers may be used.
3. No crystalline forms of silica and no lead, zinc, chromium or compounds of these elements shall be used either as fibers or bonding agent or friction modifiers.
4. The manufacturer shall provide details of constituents of the brake blocks, if requested. This information will be treated as strictly confidential. The manufacturer shall provide a material safety data sheet including the following information.
 - i. Product identification
 - ii. Ingredients
 - iii. Hazard identification
 - iv. First aid measures
 - v. Fire fighting measures
 - vi. Handling and storage
 - vii. Exposure control personal protection
 - viii. Physical & Chemical principal
 - ix. Physical & Chemical hazards
5. No materials shall be used that could constitute a health risk in normal use, nor should the wear debris from the brake block constitute a health risk.
6. Sri Lanka Railways reserves the right to analyze samples of brake blocks submitted for test. The results of such analysis will be regarded as strictly confidential.
7. In assessing the suitability of particular blocks, the Sri Lanka Railways will have regard to the emanation of obnoxious fumes & smells, or noise (Ex: squeal) arising from normal braking operation. These shall not in the opinion of the Sri Lanka Railways reach unacceptable level in the opinion of the SLR.
8. The manufacturer shall not modify the declared brake block composition, not vary the proportions of size of the constituents without prior notification and the written consent of the Sri Lanka Railway in the absence of any design requirement to the contrary the constituents shall be uniformly distributed throughout the block.

5. FINISHING OF BRAKE BLOCKS

The blocks shall be finished in a good workmanship and have uniform contour and dimensions to ensure a correct fit in brake head or holder according to Sri Lanka Railways drawing No. P 4006/00.

6. SAMPLES

Bidders should supply minimum of 60 Nos. of sample Brake Blocks for field test. Bidders who fail to submit samples along with the offer shall be rejected due to inability to test the performance.

7. TESTING OF BRAKE BLOCKS

1. Dynamometer Test

Before acceptance or purchase of blocks by Sri Lanka Railways, the manufacture shall conduct dynamometer tests, at its own expense on a full size inertia dynamometer fitted with a Railway Wheel of the correct profile to Sri Lanka Railways drawing No.L.3710/15 and part No. 02177 and 850 - 950 mm diameter. These tests should be designed to produce a profile of brake force against applied block load (KN) over the force of 18-35 KN. These results must be presented in graphical form.

The result of at least 100 tests shall be shown. The testing should be carried out on a single block wheel bases. Result must be presented for at least two different speeds, equivalent to a train speed of 32km/h and 100km/h.

2. Field Test by Purchaser

Sri Lanka Railways Authorities will conduct Field Test on Sample to conform that satisfactory stopping distances are achieved. This test will be carried out for a period of 1-2 months.

No Block will be firmly accepted as suitable for general service until, the field test is successfully completed.

- i. The Brake Block wear and associated wheel/tyre wear should be on an acceptable level.
- ii. There should not be unacceptable adverse effects on routine maintenance procedures.

8. QUALITY ASSUARANCE PROCEDURE

1. Acceptance of the brake blocks will be by conventional test and inspection supported by approved quality management system in the manufacturing plant.
2. As brake blocks are a critical safety component, it is a Sri Lanka Railways requirement that brake blocks manufacturers must have a quality management system of ISO 9001:2008 or equivalent level. Copies of current quality accreditation certificate must be provided to the Sri Lanka Railways along with the offer, before any blocks are fitted to test trains.
3. In addition the tenderers are required to include information relating to quality assurance methods used to the manufacture of brake blocks to ensure the continuing quality of the brake blocks offered.
4. All tenderers shall provide a draft of process control, inspection and test plan to be used in the quality management system with the tender. If required for perusal at the pre award discussion, the tenderness quality manual shall be made available to the Sri Lanka Railways.
5. The successful tender shall prepare within 4 weeks of award of contract a final process control inspection and test plan for written approval by Sri Lanka Railways prior to any work commencing. Any delays caused by and

unacceptable plan shall not constitute reason for an extension time to the contract completion date.

6. The manufacturer will also be required to conduct dynamometer tests on a sample drawn randomly from at least every fifth batch, to ascertain that the frictional characteristic is satisfactory. A certificate of conformity to that effect must accompany each consignment of brake blocks delivered to Sri Lanka Railways and incorporate graphs of these tests.

9. PRODUCT IDENTIFICATION

Each Brake Block shall be clearly stenciled with the grade of material, the manufacturers brand, the drawing references, batch number, etc.

10. PACKING

These blocks shall be packed in suitably strong containers to withstand rough handling, long sea voyage and storage in the open area packing shall permit easy forklift or crane handling.

11. WARRANTY

- I. The Brake Blocks offered should be guaranteed as stipulated in the clause 27 of Conditions of Contract applicable to this Bid against faulty design, inferior material or manufacturing defects for a period of one year from the date of acceptance by Sri Lanka Railways.
- II. Prospective Bidders should clearly indicate details of the warranty conditions given by them for Brake Blocks offered.

3. Drawings

These Bidding Documents includes the following drawing.

List of Drawings			
Drawing No.	Drawing Name	Purpose	Remarks
S2678/03	DRAWING FOR HIGH FRICTION BARAKE BLOCKS	To conformity	Refer 65.A
L3710/15	ORDERING SPECIFICATIONS FOR LOCO, C&W AND PCC TYRES	To conformity	Refer 65.B
P 4006/00	BRAKE BLOCK HOLDER	To conformity	Refer 65.C

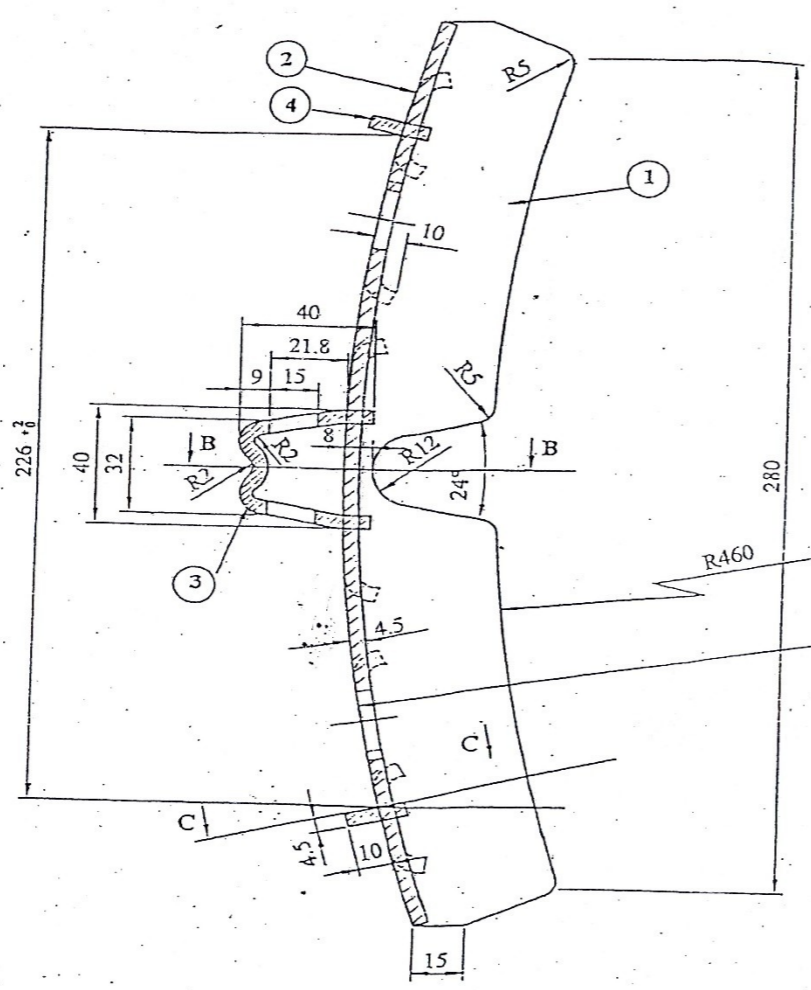
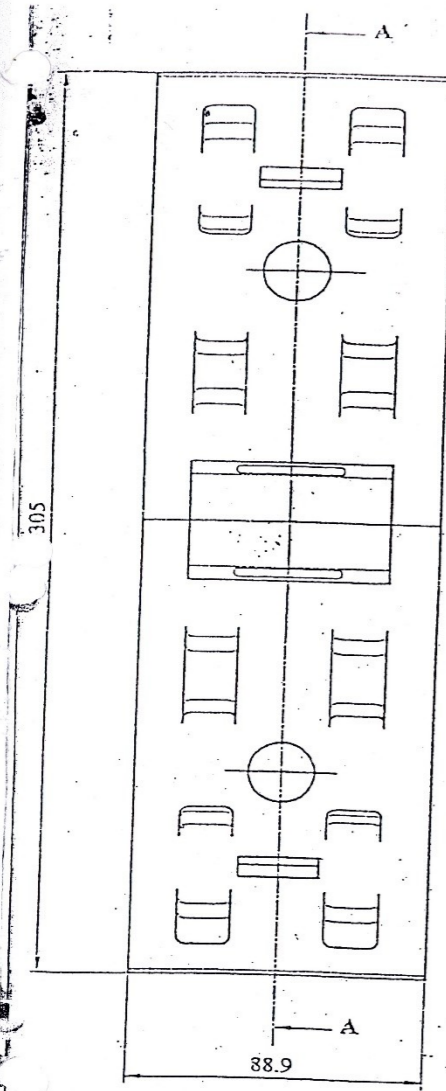

SECTION A-A

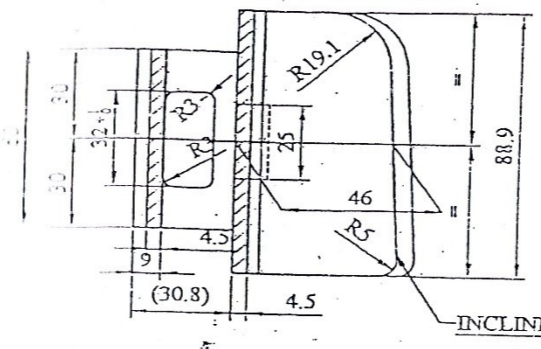

SECTION B-B

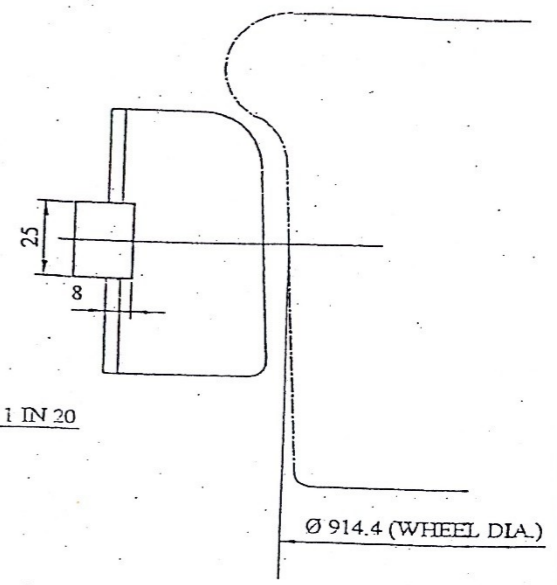

SECTION C-C

AXLE LOAD - 16.5TON
 MAX. SPEED - 100 kmph
 FRICTION COEFFICIENT - 0.3
 WHEEL MATERIAL - BS 5892 OF 1992 : PART 3 : GRADE R9T
 BRAKE FORCE PER BLOCK - 18 kN
 CHANGE OF COEFFICIENT OF FRICTION WITHIN THE TEMPERATURE RANGE OF 30° - 120° SHOULD BE LESS THAN 0.05
 MAXIMUM EXTENSION OF STOPPING DISTANCE ALLOWED IS 11% AT A SPEED OF 80 kmph.

FIGURE NO - RMS 78/73/02 -

ALL DIMENSIONS ARE IN mm.

PART NO	DESCRIPTION	MATERIAL	QTY.	REMARKS
	STOPPER	SS 41 TO JIS 3101	02	
	HANGER	SS 41 TO JIS 3101	01	
	BASE PLATE	SS 41 TO JIS 3101	01	
	BRAKE SHOE	RESIN	01	
	ORIGINAL			
	HARDENED & GRIND			
	FINISH FOR HARDENING & GRIND			
	CASE HARDENED & GRIND			
	SKIN HARDENED			

DRG. NO. SLR / ATU / S8 / 312
 DRG. NO. REFERENCE DRGS.
 DRG. NO. S 2678/02

INDIA RAILWAYS - MECHANICAL DEPARTMENT

ALTER SLIP NO. TITLE :- COMPOSITION BRAKE BLOCK
 SUB-DIVISION :- S 8 & S9
 DIVISION :- PLANT & MACHINERY

SCALE :- 1:2
 DRAWER NO. DNO S 2678/02

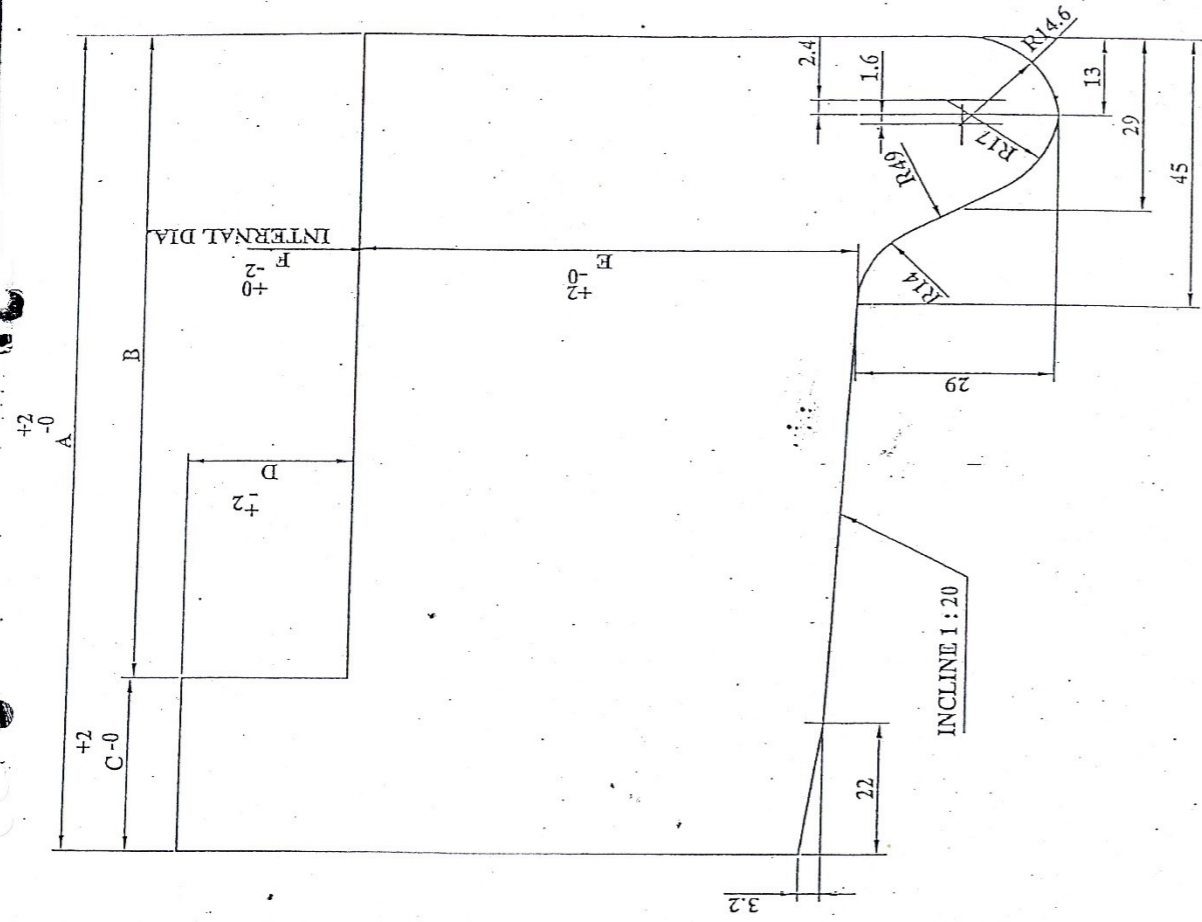

NOTE:-

1. S.L.R. insists that the material should be strictly in accordance with BS 5892: pt.4:1992 grade B6 E. However, equivalent standards will be considered provided that the tenderers submit all the parameters of such standards to the satisfaction of S.L.R.

2. If the S.L.R. so decides, the inspection will be arranged in accordance with BS 5892: pt.4:1992. The tenderer should provide necessary assistance to the inspector appointed by S.L.R.

GRADE B6 E STEEL TO BS 5892:Pt4:1992

MATERIAL	PART NO	DESCRIPTION	STORE NO.	A-0	B	C-0	D	E	+2	+0	-0	FINISH TYRE	DRG.NO.
	02178	DRIVING & COUPLED WHEELS - Y	RY 76/04/1	137	105	32	25	78	940	L3427/12/B			
	D 16111	DRIVING WHEELS - M8	RDM 76/04/01	137	108	29	25	56	983				
	02177	DRIVING WHEELS - S5,S6,S7,S8,S9,W1,W2,M4, M5,M7 & M9 AND CARRIAGE & WAGON WHEELS (3'-0" DIA) B.G INCLUDING CHINESE 4 WHEELS WAGON	RW 76/04/1	137	105	32	25	94	762				
	D 16094	IDLER WHEELS - M6	RBM 76/02/3	137	108	29	25	84	670	TL 110-265 -00			
	D 16093	DRIVING WHEELS - M6	RBM 76/01/8	137	108	29	25	83	864	TL 110-263 -00			
	D 1610	IDLER WHEELS - M2, M2B, M2D	RNMM 76/04/2	137	108	29	25	75	641	L 684/05			
	D 1609	DRIVING WHEELS - M2, M2D	RNMM 76/04/1	137	108	29	25	75	896	L3427/12/B			
	02132	CARRIAGE & WAGON WHEELS (3'-7 3/4" DIA) B.G.	RG 1/04/1	137	105	32	16	75	965	P 2175/03			
				+2	A-0	B	C-0	D	E	+2	+0	-0	F-2
			STORE NO.	A-0	B	C-0	D	E	+2	+0	-0	F-2	DRG.NO.

ALL DIMENSIONS IN MILLIMETERS

SUPERSEDES DRG. NO. L 3710/14
SUPERSEDED BY DRG. NO.

DRG. NO. REFERENCE DRGS.

SRI LANKA RAILWAYS - MECHANICAL DEPARTMENT

DRAWN BY: *Handwritten* ALT. SLIP NO. TITLE: ORDERING SPECIFICATIONS FOR LOCO, C&W AND PCC TYRES

CHECKED BY: *Handwritten* SUB DIVISION:

APPROVED (MED): *Handwritten* DIVISION: B. G. LOCOMOTIVES, C & W

APPROVED (CMB): *Handwritten*

INCHES BY: *Handwritten* SCALE: DRAWER NO: 106 D. NO. L 3710/15

DATE: 04.09.2008

65-B

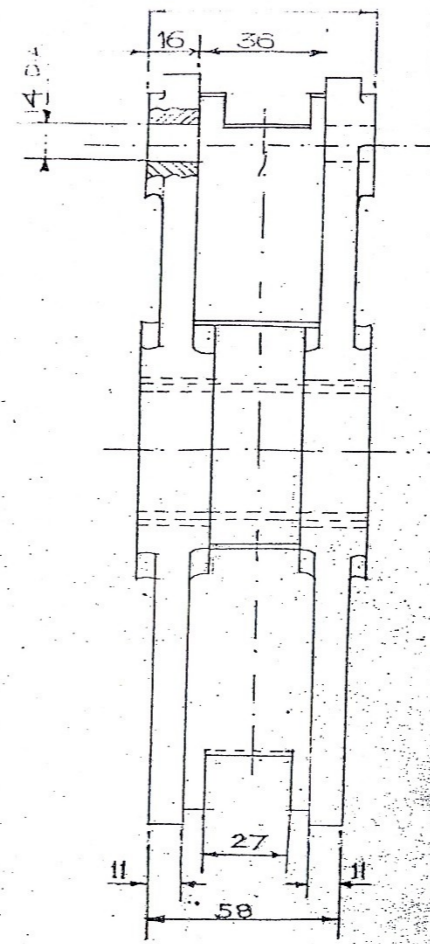
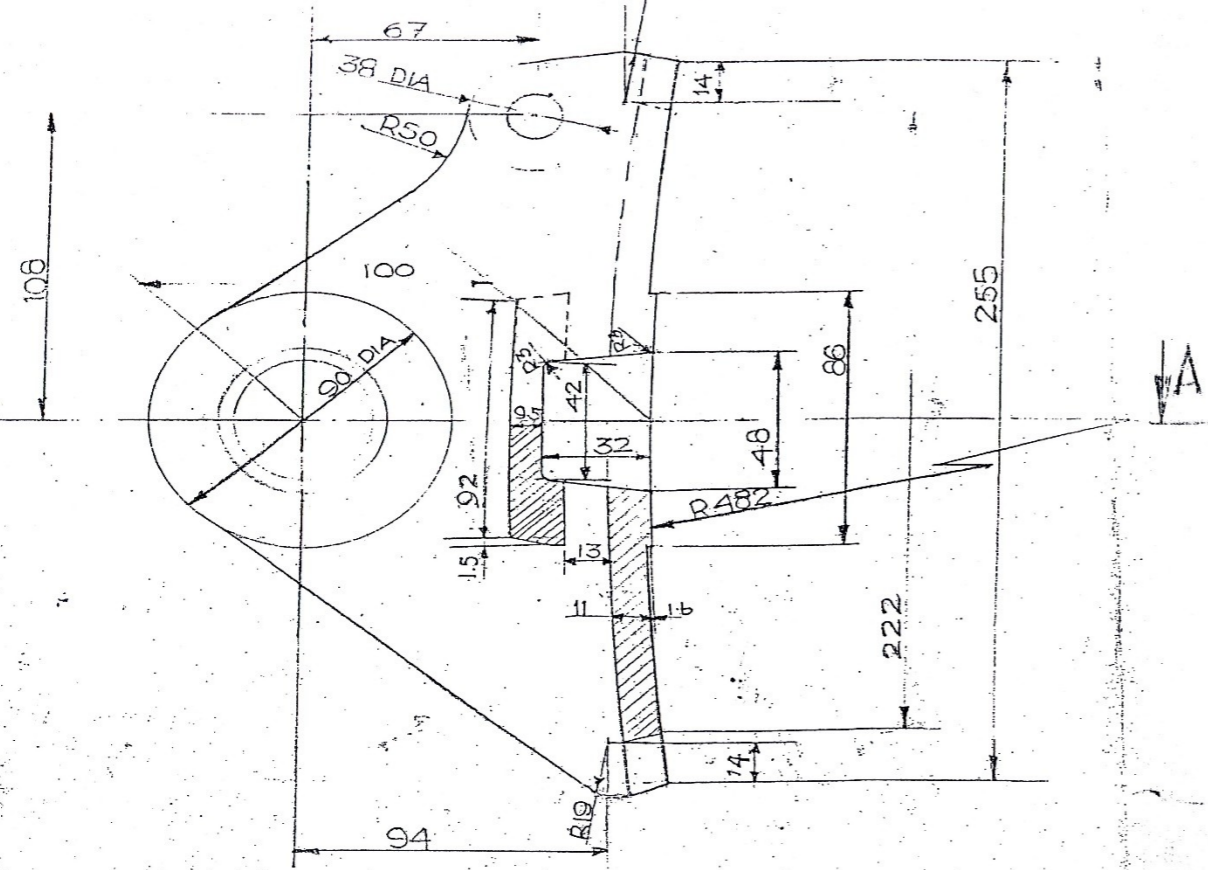

65-C

SECTION A-A

MATERIAL - CAST IRON
 PART NO - 441051
 NO PER BOSS - 8
 STORE NO - RG 3/01/13

P 4006/00

TO PART NO D-0663 OF
 DRG. NO DE 2529/00 FOR
 HITACHI SETS
 TO PART NO 441029 OF
 DRG. NO P 3966/00 FOR ROMANIAN COACH

ALL DIMENSIONS ARE IN MILLIMETERS

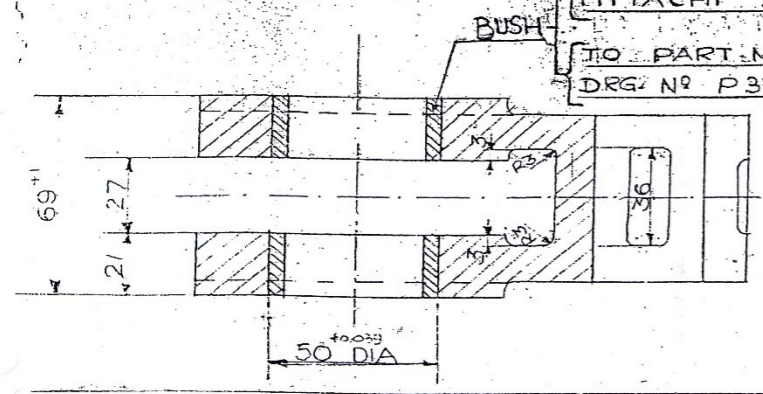

DESIGNED BY	APPROVED BY	DATE	SCALE
DRAWN BY	CHECKED BY	APPROVED BY	DATE
CEYLON GOVERNMENT RAILWAY - MECH			
SUPERSEDED BY DRG. NO.		D. NO.	
SUPERSEDED BY DRG. NO.		D. NO.	
TITLE - BRAKE BUSH			
SUB-DIVISION - PAVANA			
DIVISION - ROMANIAN			
DRAWN BY			
CHECKED BY			
APPROVED BY			
DATE			

P 4006/00

Section VII. Contract Data

The following Contract Data shall supplement and / or amend the Conditions of Contract (CC). Whenever there is a conflict, the provisions herein shall prevail over those in the CC.

CC 1.1	The Purchaser is: Sri Lanka Railways The name and identification number of the contract are, Procurement for the supply of 45,000 Nos. High Friction Composite Brake Blocks IFB No. SRS/F. 8017
CC 4.5	Add the following to CC 4: For purpose of the Contract “FOB”, “CIF” and other trade terms used to describe the obligations of the parties shall have the meanings assigned to them by the current edition of INCOTERMS published by the International Chamber of Commerce, Paris.
CC 7.1	The goods supplied under this contract shall conform to Railway Stores Specifications issued with this Bid. Copies of the ISO 9001:2008 for the design and manufacture of each of the items to be supplied shall be submitted with the offer. Eligible Bidders: <ol style="list-style-type: none">i. All bidders shall possess legal rights to supply the Goods under this Contract.ii. A bidder shall not have a conflict of interest. All bidders found to have conflict of Interest shall be disqualified. Bidders may be considered to have a conflict of interest with one or more parties in this bidding process, if they submit more than one bid in this bidding process.iii. A bidder that is under a declaration of ineligibility by the National Procurement Agency (NPA) at the date of submission of bid or at the date of Contract Award, shall be disqualified. The list of debarred firms is available at the website of NPA, www.npa.gov.lk.iv. The manufacturer of the item shall submit the documentary evidence to prove the potential and experience in manufacturing and supplying High Friction Composite Brake Blocks for the use of air brake operated Railway coaches by providing at least three (3) Nos. duly completed purchase orders per annum for the last 5 years for similar supplies.v. The manufacturer of the item shall have completed at least three (03) bulk orders of the item during last three (03) years and one out of them shall be supplied to a Railway organization outside the country of the manufacture.vi. Manufacturer shall provide at least five (05) end user certificates/Performance certificate for already sold High Friction Brake Blocks for orders completed within last five (05) years up to the date of bid submission. Out of that, one should be outside the country of manufacturer,

CC 8.1

For **Notices**, the Purchaser's address shall be:

Attention: The General Manager.

Address: Sri Lanka Railways,
Railway Headquarters, ,
Olcott Mawatha,
Colombo 10, Sri Lanka.

Telephone: 94 (11) 2431177

Facsimile number: 94(11) 2446490

Electronic mail address: gmrslr@sltnet.lk

CC 12.1

Goods shall be shipped as follows,

First batch (15,000 Nos.) - Fourteen (14) weeks from the date of opening of L/C.

Second batch (15,000 Nos.) - Thirty (30) weeks from the date of opening of L/C.

Third batch (15,000 Nos.) – Forty five (45) weeks from the date of opening of L/C.

1. Upon shipment, supplier shall notify the Purchaser by Fax, the full details of the shipment, including Contract Number, Description of Goods, Quantity, Name of the Vessel, Number of the Bill of Lading and the date, Port of Loading, Date of Shipment, Port of discharge with the expected date of arrival.(Fax No.94 (11) 2446490.

2. The Following are the documents, the supplier shall submit to the negotiation bank after shipment of goods.

(a) Full set of not less than three copies (original and two copies) of clean on board, freight pre-paid/to pay Bill of Lading to order of the Peoples' Bank, International Branch, Colombo, Marked:-

General Manager,
Sri Lanka Railways,
Colombo 10,
Sri Lanka.

Order No: SRS/F.8017.

(b) Manually signed Invoices in triplicate showing the FOB value and freight and insurance charges separately.

(c) Certificate of Origin in triplicate issued / certified by the Chamber of Commerce of the Manufacturing country.

(d) Packing List in triplicate indicating the weight and measurements of each package/case/bundle/crate.

(e) Certificate of Inspection in triplicate issued by the inspector nominated by the purchaser in triplicate.

(f) Letter of Acceptance of the inspection certificate issued by the purchaser in triplicate.

(g) A certificate from the supplier to the effect that.-

i) The goods shipped are in strict conformity with the order placed by the purchaser.

ii) All packages / bundles / cases / crates are marked with a RED BAND in the centre in each

<p>CC 15.1</p>	<p>direction, so as to form a cross on each face to be visible on which-ever side the packages / cases / bundles / crates are placed.</p> <p>iii) The following shipping mark is stenciled including the gross weight in kilograms and package number on two adjacent faces of each package, and metal labels are attached securely to loose or bundled articles.</p> <p style="text-align: right;">Order No: SRS/F.8017. Deputy General Manager (Procurement), Sri Lanka Railways, P.O. Box 1347, Colombo 10, Sri Lanka. Weight:.....kg. Package No.</p> <p>iv) The Supplier shall forward copies of the above documents in duplicate to the purchaser by Courier Service immediately on shipment of goods. In case of a local supplier (Import and supply basis) The Local supplier shall deliver the goods to Rathmalana stores, Sri Lanka Railways as follows First batch (15,000 Nos.) - Fourteen (14) weeks from the date of placing the order. Second batch (15,000 Nos.) - Thirty (30) weeks from the date of placing the order. Third batch (15,000 Nos.) - Forty five (45) weeks from the date of placing the order.</p> <p>Payments shall be made as follows;</p> <p>a) 90% of the Contract price of the goods delivered (less Local Agency commission) shall be paid through Irrevocable and without recourse Letter of Credit opened in favour of the Supplier upon submission of documents specified in CC 12 and in the Letter of Credit.</p> <p>b) 05% of the Contract price of the goods delivered shall be paid upon arrival and acceptance of the goods by the Purchaser against a certificate of acceptance issued by the General Manager, SLR.</p> <p>c) The balance 05% of the contract price of the delivered goods shall be paid in completion of the contract pursuant to Clause 27 of CC.</p>

	<p>Payments in the case of a Local supplier shall be made as follows.</p> <ul style="list-style-type: none"> a) 95% of contract price of the goods delivered shall be paid upon the submission of a certificate issued by Chief Engineer (Motive Power), Dematagoda, Sri Lanka Railway that the goods supplied confirm to SLR specification as per Clause 25 of CC. b) The balance 05% of the Contract Price of the goods delivered shall be paid on completion of the contract pursuant of Clause 27 of CC. <p>The purchaser shall released the payment specified under c above at the request of the supplier, provided the supplier submits a Bank Guarantee as per the specimen form given in Section VIII issued by a registered Bank operating in Sri Lanka, acceptable to the purchaser.</p>
CC 16.1	<p>For goods manufactured outside the Purchaser's Country, the Supplier shall be entirely responsible for all taxes, stamp duties, license fees, and other such levies imposed outside the Purchaser's Country.</p>
CC 17.1	<p>A Performance Security:</p> <p>The amount of Performance Security, as a percentage of the contract price, shall be ten percent (10%) of the Contract Price.</p> <p>Within fourteen (14) days of receipt of the Notification of Award of the Contract the successful Bidder shall furnish to the Purchaser an on demand performance security.</p>
CC 22.1	<p>During transit, the packing shall be sufficient to withstand, without limitation, rough handling and exposure to extreme temperatures, salt and precipitation, and open storage. Packing case size and weights shall take into consideration, where appropriate, the remoteness of the goods' final destination and the absence of heavy handling facilities at all points in transit.</p> <p>These Blocks shall be packed in suitably strong containers to withstand rough handling, long sea voyage and storage in the open area packing shall permit easy forklift or crane handling. Type of packaging should be proposed for approval.</p> <p>The packing, marking, and documentation within and outside the packages shall comply strictly with such special requirements as shall be expressly provided for in the Contract, including additional requirements, if any, and in any other instructions ordered by the Purchaser.</p> <p>The packing, marking and documentation within and outside the packages shall be:</p> <ul style="list-style-type: none"> i. All packages / bundles / cases / crates are marked with a RED BAND in the center in each direction, so as to form a cross on each face to be visible on which-ever side the

	<p>packages / cases / bundles / crates are placed.</p> <p>ii. The following shipping mark is stenciled including the gross weight in kilograms and package number on two adjacent faces of each package, and metal labels are attached securely to loose or bundled articles.</p> <p>Order No: SRS/F.8017</p> <p>Superintendent of Railway Stores, Sri Lanka Railways, P.O. Box 1347, Colombo 10, Sri Lanka.</p> <p>Weight:.....kg.</p> <p>Package No.</p>
CC 24.1	<p>Responsibility for arranging transportation of the Goods shall be in accordance with the specified Inco-terms. CIF transport of the Goods to the Port of Colombo, Sri Lanka shall be arranged and paid for by the supplier, and the cost thereof shall be included in the quoted CIF Contract Price.</p> <p>The goods shall be shipped by the vessels of the Ceylon Shipping Corporation Ltd. If there are no vessels sailing from the Port of Shipment during the period, a waiver may be obtained from the Ceylon Shipping Corporation Ltd, to ship the goods in other vessels.</p>
CC 25.1	<p>The inspections and tests shall be:</p> <p>a) Where specified, the goods shall be inspected by the Inspector, who may approve or reject the goods, and if the goods are found defective or inferior in quality or differing in form or material from the requirements of the contract it may be completely rejected.</p> <p>The supplier shall, at his own expense and within the time for delivery specified in the contract, replace to the satisfaction of the SLR, the material so rejected.</p> <p>b) Before proceeding to execute any production, the supplier shall obtain the inspector's approval for the manner in which the supplier proposes to execute each portion of the supply, and shall furnish such drawings or information as the inspector shall require.</p> <p>c) The Supplier shall notify the inspector in writing, with at least 30 calendar days of notice, of the date on which any of the supply will be ready for inspection.</p> <p>d) Without prejudice to the Inspector's right of final Inspection under Paragraphs (a) and (b) of this Clause, the inspector may inspect and reject any of the goods in the course of production.</p>

	<p>e) Where inspection of any of the goods, whether completed or in the course of production, is being performed at the manufacturer's premises, the manufacturer shall give the inspector access to the said premises as and when required and shall afford the representative all such reasonable accommodation and facilities for examining, inspecting, testing and gauging such items and shall also supply free of charge such apparatus, materials, tools gauges, labour and assistance as may be required from time to time for the purpose of such examination, inspection, testing and gauging.</p> <p>f) If any of the goods, whether completed or in the course of production is rejected by the inspector, it shall be marked or segregated in such a manner, satisfactory to the inspector as to ensure its subsequent identification as rejected goods.</p> <p>When independent tests in addition to those made by the inspector on the manufacturer's premises are considered necessary, such tests will be made by the person appointed by the inspector. The supplier shall bear the cost of supply and carriage of samples. The cost of such additional tests will be borne by the Sri Lanka Government if such tests show the material to be in accordance with the specifications, otherwise such cost shall be borne by the supplier.</p> <p>Until the inspector has given his certificate of approval, the supplier/manufacturer shall not assemble or send forward for shipment any of the goods, and should any defect be discovered after dispatch from the manufacturer's goods, it shall be subject to and covered by the guarantee stipulated in Clause 4 of SCC hereof, notwithstanding any certificate or approval previously issued by the Inspector.</p> <p>g) The inspected and passed goods shall not be released for shipment until confirmation of the acceptance of the pre-shipment inspection certificate is obtained by the inspector from the Purchaser.</p>
CC 25.3	<p>a) In case of a local supplier who supplies the brake blocks on the basis of import and supply, supplier shall be taken the responsibility of supplying the goods as per the SLR specification. Payment will be released after testing the satisfactory performance of the random samples from the bulk supply. Deviation will not be considered and supplier should be taken the responsibility to replace the goods.</p> <p>b) If local supplier required, the purchaser or its designated representative can be arranged to attend the tests and/or inspections referred to in CC Sub-Clause 25.1 but all expenses shall be born by the local supplier.</p>
CC 26.1	<p>The liquidated damage shall be 0.5% per week and the maximum amount of liquidated damages shall be 05%.</p>

CC 27.3	<p>The supplier will be required to guarantee the goods supplied for a period of twelve (12) months from the date of acceptance by the purchaser.</p> <p>The Performance Security shall be valid until the end of the warranty period.</p> <p>The 05% for the contract price retained as per Clause 15.1 above will be released after the successful completion of the total guarantee period.</p>
CC 27.5	<p>The supplier will accordingly be required to replace within the period of three (03) months, free of cost including labour costs for removal and refitting the goods, which fails during the guarantee period of twelve (12) months owing to faulty design, inferior material or manufacturing defects.</p>
CC 36	<p>COUNTRY OF ORIGIN</p> <ol style="list-style-type: none"> a. The country of origin shall be clearly stated by the Bidder for each item to be purchased in the offer. b. For purposes of this clause “Origin” means the place where the Goods were mined, grown or manufactured or from which the Services are supplied. c. The origin of Goods and Services is distinct from the nationality of the supplier.

Invitation for Bids

SRI LANKA RAILWAYS

PROCUREMENT OF 45,000 NOS. HIGH FRICTION COMPOSITE BRAKE BLOCKS – SRS/F.8017

1. The Chairman, Department Procurement Committee (Major) on behalf of Sri Lanka Railways, Railway Head Quarters, P.O. Box 355, Colombo, Sri Lanka will receive sealed bids from eligible and qualified bidders for the Supply of 45,000 Nos. High Friction Composite Brake Blocks to Sri Lanka Railways. Bidders may submit their bids through an accredited agent empowered by them with Power of Attorney.
2. Bidding will be conducted through International Competitive Bidding.
3. Interested eligible bidders may obtain further information and inspect the Bidding Documents at the address given below from 9.00am to 3.00pm.

Deputy General Manager (Procurement),
Railway Procurement Sub Department,
Olcott Mawatha,
Colombo 10, Sri Lanka.

Telephone Nos. : 94 (11) 2438078 or 94(11) 4600202

Fax No. : 94(11) 2432044

Email : srs.slr@gmail.com, tender1@railway.gov.lk

Website : www.railway.gov.lk

4. The manufacturer of the item shall have experience of more than five (05) years in manufacturing and supplying High Friction Composite Brake Blocks for the use of air brake operated Railway coaches/DMU.
5. The bidder should have ISO 9001:2008 or equivalent for manufacturing High Friction Brake Blocks for more than 05 years or the manufacturer/Supplier should have completed at least three (03) years and one out of which should be to a foreign Railway.
6. a. Any person who acts as an agent or sub agent, representative or nominee for or on behalf of any bidder shall register himself before submission of bids with Registrar of Public Contracts Sri Lanka, as required by the Public Contract Act No.03 of 1987. The Original Certificate of registration shall be submitted with the bid. The bids of those bidders who fail to submit such original certificate shall be rejected.
b. The bidders shall also register themselves immediately after submission of the bids and prior to the award of the procurement, in terms of the Public Contract Act No.03 of 1987. The procurement shall not be awarded to any bidder unless such bidder had submitted the Certificate of Registration issued in terms of the Public Contracts Act to the relevant Procurement Committee.
7. A complete set of Bidding Documents in English Language may be purchased by interested bidders on the submission of a written application to the address of the Deputy General Manager (Procurement), Railway Procurement Sub Department, Olcott Mawatha, Colombo 10, Sri Lanka.or Sri Lanka Missions abroad from

05/12/2024 to **21/01/2025** up to 3.00 p.m. (Sri Lanka Time) on payment of a non-refundable procurement fee of **Rs. 53,000/-** only or an equivalent sum in a freely convertible currency.

8. Bids must be delivered to the address below on or before **2.00 p.m. on 22/01/2025**

The Chairman,
Department Procurement Committee (Major)
Sri Lanka Railways
Railway Procurement Sub Department
Olcott Mawatha, Colombo 10, Sri Lanka.

Late bids will be rejected. Bids will be opened in the presence of the bidders' representatives at Room No. 01, 3rd Floor, Railway Procurement Sub Department, P.B. 1347, Olcott Mawatha, Colombo 10, Sri Lanka at **2.00 p.m. on 22/01/2025**

The Chairman,
Department Procurement Committee (Major)
Sri Lanka Railways.

Ref No. SRS/F.8017.

THE LIST OF FOREIGN MISSIONS ABROAD

1. The Ambassador for the Democratic Socialist Republic of Sri Lanka in Austria, Belgium, France, People's Republic of China, Cuba, Egypt, Berlin, Indonesia, Iran, Iraq, Italy, State of Israel, Japan, Jordan, Republic of Korea, State of Kuwait, Lebanon, Myanmar, Katmandu, The Netherlands, Sultanate of Oman, The Philippines, Poland, State of Qatar, Russian Federation, Kingdom of Saudi Arabia, Sweden, Thailand and U.A.E.
2. The High Commissioner for the Democratic Socialist Republic of Sri Lanka in Australia, Bangladesh, Canada, India, Kenya, Malaysia, Republic of Maldives, Pakistan, Singapore, South Africa and United Kingdom.
3. The Consulate General of the Democratic Socialist Republic of Sri Lanka in Australia, Canada, Bonn, India, Norway, Pakistan, Kingdom of Saudi Arabia, U.A.E and Los Angeles
4. The Deputy High Commissioner of the Democratic Socialist Republic of Sri Lanka in Chennai.
5. Permanent Mission of the Democratic Socialist Republic of Sri Lanka in U.S.A. and Switzerland.

